

JTCCM

Issued on June 1, 2000

Amended on August 2, 2001

Amended on December 7, 2001

Amended on July 14, 2003

Amended on October 18, 2004

# **Fire Preventive and Fireproof Performance Test and Evaluation Procedure Manual**

## Table of Contents

1. Scope .....	2
2. Required Documents on Application for Evaluation .....	2
3. Evaluation Procedure .....	3
4. Fire Preventive and Fireproof Performance Test and Evaluation Procedures .....	5
4.1 Fireproof performance test and evaluation procedure .....	5
4.2 Quasi-fireproof performance test and evaluation procedure .....	15
4.3 Fire preventive performance test and evaluation procedure.....	25
4.4 Quasi-fire preventive performance test and evaluation procedure .....	31
4.5 Roof flame insulating performance test and evaluation procedure .....	36
4.6 Floor Fire Preventive Performance Test and Evaluation procedure .....	40
4.7 Eaves Flame insulating performance test and evaluation procedure.....	45
4.8 Fire preventive performance testing and evaluation method for columns .....	50
4.9 Flame insulating and quasi-flame insulating performance test and evaluation procedure .....	54
4.10 Noncombustibility test and evaluation procedure .....	62
4.11 Quasi-noncombustibility test and evaluation procedure.. ..	76
4.12 Fire-retardant performance test and evaluation procedure .. ..	85
<b>4.13 Testing and Evaluation Procedure for Ember Ignition Performance of Roofing Materials.....</b>	<b>113</b>
<b>5. Performance Evaluation Report .....</b>	<b>119</b>

## 1. Scope

The scope covers the evaluation required by the regulations from (1) to (18) listed below (Law and Order as used hereafter refer to the Building Standard Law of Japan and Building Standard Law Enforcement Order, respectively):

- (1) Item (7), Article 2, Law (excluding columns)
- (2) Item (7-2), Article 2, Law (excluding columns)
- (3) Item (8), Article 2, Law
- (4) Item (9-2-b), Article 2, Law
- (5) Article 23, Law
- (6) Article 64, Law
- (7) Item (1), Article 109-3, Order
- (8) Item (2-c), Article 109-3, Order
- (9) Paragraph 1, Article 112, Order
- (10) Item (3) Paragraph 1, Article 113, Order
- (11) Paragraph 5, Article 114, Order
- (12) Item (4) Paragraph 1, Article 115-2-2, Order
- (13) Item (1) Paragraph 1, Article 115-2-2, Order (excluding columns)
- (14) Item (4-c) Paragraph 1, Article 115-2-2, Order
- (15) Item (7-c) Paragraph 1, Article 129-2-5, Order
- (16) Item (9), Article 2, Law
- (17) Item (5), Article 1, Order
- (18) Item (6), Article 1, Order
- (19) Paragraph 1, Article 22, Law
- (20) Article 63, Law

## 2. Required Documents on Application for Evaluation

The following documents are required on application for evaluation. Forms and other conditions shall be as separately specified.

- (1) Application form for performance evaluation
- (2) Figures explaining the detail on the structural system
- (3) The specifications of materials composing of the structural systems
- (4) Standard construction procedure
- (5) Explanatory statement specifications

- (6) Applicant's Detail
- (7) Miscellaneous

### 3. Evaluation Procedure

Evaluation should be conducted according to the following procedure:

- (1) Evaluators nominated in each of the performance evaluation categories shown in Table 1 should perform evaluation according to the test and evaluation methods listed in Section 4 and the submitted documents listed in Section 2.
- (2) Evaluators should request applicants for clarification on any items related to the submitted documents shown in Section 2 if they find it necessary in order to perform the evaluation.

**Table 1 Categories of performance evaluation and evaluation methods**

Categories specified by Article 59, Ministry Order	Categories specified by regulations of the Law and Order		Testing and evaluation procedures for fire preventive/fireproof performance
	Applicable provisions	Construction, material, etc.	
Type 1	Item (7), Article 2, Law	Fireproof construction (excluding columns)	Fireproof performance test and evaluation procedure
	Item (7-2), Article 2, Law	Quasi-fireproof construction (excluding columns)	Quasi-fireproof performance test and evaluation procedure
	Item (8), Article 2, Law	Fire preventive construction	Fire preventive performance test and evaluation procedure
	Item (9-2-b), Article 2, Law	Fire doors and other fire preventive equipment	Flame insulating and quasi-flame insulating performance test and evaluation procedure
	Article 23, Law	Quasi- fire preventive construction	Quasi-fire preventive performance test and evaluation procedure
	Article 64, Law	Fire preventive equipment for openings of external walls	Flame insulating and quasi-flame insulating performance test and evaluation procedure
	Item (1), Article 109-3, Order	Roof of a building with same level of fireproof performance as a quasi-fireproof building	Roof flame insulating performance test and evaluation procedure
	Item (2-c), Article 109-3, Order	Floors and ceilings directly beneath those of a building with same level of fireproof performance as a quasi-fireproof building	Floor fire preventive performance test and evaluation procedure
	Paragraph 1, Article 112, Order	Designated fire preventive equipment	Flame insulating and quasi-flame insulating performance test and evaluation procedure

Categories specified by Article 59, Ministry Order	Categories specified by regulations of the Law and Order		Testing and evaluation procedures for fire preventive/fireproof performance
	Applicable provisions	Construction, material, etc.	
	Item (3) Paragraph 1, Article 113, Order	Roof of part of a building where the fire wall is constructed	Roof flame insulating performance test and evaluation procedure
	Paragraph 5, Article 114, Order	Fire preventive equipment used at separation walls, partition walls and dividing walls made of quasi-fireproof construction	Flame insulating and quasi-flame insulating performance test and evaluation procedure
	Item (4) Paragraph 1, Article 115-2, Order	Floors of a building which requires no fire walls	Floor preventive performance test and evaluation procedure
	Item (1) Paragraph 1, Article 115-2-2, Order	Principal building parts (excluding columns) of a special building that requires no fireproof building	Quasi-fireproof performance test and evaluation procedure
	Item (4-c) Paragraph 1, Article 115-2-2, Order	Eaves, etc. of a special building that requires no fireproof building	Flame insulating performance test for eaves, etc. and evaluation procedure
	Item (7 c), Paragraph 1, Article 129-2-5, Order	Pipes, etc. that penetrate fire compartments, etc.	Flame insulating and quasi-flame insulating performance test and evaluation procedure
Type 2	Item (9), Article 2, Law	Noncombustible material	Noncombustibility test and evaluation procedure
	Item (5), Article 1, Order	Quasi-noncombustible material	Quasi-noncombustibility test and evaluation procedure
	Item (6), Article 1, Order	Fire retardant material	Fire-retardant performance test and evaluation procedure
Type 3	Paragraph 1, Article 22, Law	Structure of the roof which exposed to a normal fire	<b>Ember Ignition Performance of Roofing Materials</b>
	Article 63, Law	Structure of the roof which exposed to a urban area fire	<b>Ember Ignition Performance of Roofing Materials</b>

## 4. Fire Preventive and Fireproof Performance Test and Evaluation Procedures

### 4.1 Fireproof performance test and evaluation procedure

Performance evaluation required by Article 2 item (7) of the Law (Fireproof Construction) shall be conducted by the following test and evaluation procedure:

#### 1. General

- (1) Fireproof performance test shall be conducted on a set of specimen specified in 2, and measured as specified in 5 by using the test equipment specified in 3, under the test conditions specified in 4. If the measurement result satisfies the judgment criteria specified in 6, the specimen shall be judged as classified.
- (2) Fireproof performance test shall be given to each side of the component which is confirmed to be simultaneously exposed to the heat of fire. This rule shall not be applied to some types of wall as an exception if any exposure side of the wall is clearly confirmed that it is as fireproof as or more fireproof than other sides by the fireproof performance test separately conducted by a designated performance evaluation body. In this case, the fireproof performance test may be omitted for that side of the wall.

#### 2. Specimen

- (1) The composition and the material of the specimen shall be representing the actual product system. Providing that the actual component has two or more variations with different specifications, either a) or b) in the following shall apply:
  - a) In case there are two or more types of sectional lack caused by grooving or other surface treatment given onto the surface of the fireproof cladding, the type that has the largest total volume of lack shall be used as a specimen.
  - b) In case there are two or more types of composition or configuration for the surface of the fireproof cladding, the type that has the greatest mass of organic compounds shall be used as a specimen.
- (2) Dimensions, composition, and density of a specimen shall be within the allowable range.

- (3) The number of specimens shall be two for each surface to be heated, as provided for in (2) of 3. herein, unless otherwise specified. The exception is walls with a symmetrical section, for which the test to either side may be omitted.
- (4) The form and size of a specimen shall be identical to the actual product system except in cases where testing with a specimen sized identical to the actual tone is extremely difficult. In such cases, the form and size of a specimen may be changed providing that the form of a specimen and the area to be heated may be either a) to f) as specified in the following or that the fireproof performance of the specimen shall be kept the same by maintaining the original material and composition, the original fireproof cladding application intervals, or the original spacing of studs or furring strips.
- a) For walls, the specimen shall be a rectangular panel measuring a minimum of 3,000 mm in width, a minimum of 3,000 mm in height, and as thick as the actual product system.
- b) For floors, the specimen shall be a rectangular panel, the form and size of a specimen shall be either [1] or [2] as follows;
- [1] If the lower surface will be heated, the dimensions shall be at least 4,000 mm on the longer, a minimum of 3,000 mm in shorter side (or a minimum of 2,000 mm if the specimen is only supported by the shorter side), and as thick as the actual component system.
- [2] If the upper surface will be heated, the dimensions shall be at least 2,000 mm on the longer side and 1,800 mm on the shorter side, and the thickness shall be the same as in the actual component system.
- c) For roofs, the specimen shall be a rectangular panel measuring a minimum of 4,000 mm in longer side, a minimum of 3,000 mm in shorter side (or a minimum of 2,000 mm if the specimen is only supported by the shorter side), and as thick as the actual component system.
- d) For beams, the form and size of the section of the specimen shall be identical to that of the actual component system, and its minimum length shall be 3,000 mm. For steel frame used as a specimen of the steel construction beam, the standard specimen dimension shall be H - 300 mm × 300 mm × 10 mm × 15 mm.

However, instead of these dimensions, specimens of columns that include base-isolation materials made using laminated rubber (hereinafter referred to as “base-isolation materials”) may be based on specifications that provide for at least

200 mm of column material above with the upper and lower connections reproduced.

- e) For beams, the form and size of the section of the specimen shall be identical to that of the actual component system, and its minimum length shall be 4,000 mm. For steel frame used as a specimen of the steel construction beam, the standard specimen dimension shall be H - 400 mm × 200 mm × 8 mm × 13 mm.
  - f) For stairs, the form and size of the section of a treadboard and of a beam supporting the treadboard shall be identical to that of the actual component system, and its minimum width shall be 1,200 mm and the number of steps is a minimum of 5.
- (5) For the fixing interval of fireproof cladding for specimens, the greatest interval among the intervals actually practiced shall be set.
  - (6) In cases where weak points, such as joints, from the viewpoint of fire proof property may appear when building construction is actually executed using these parts, the weak points shall be placed in the middle of the specimen. Application of fireproof cladding shall be so arranged as to include as many weak points, such as joints, as possible within the effective heated area. For joints of a specimen to be tested for tiling or other setting performance, straight joints with continuous straight joints both in the vertical and horizontal direction shall be used.
  - (7) In case no sealant is specified for use in joints of fireproof cladding, acrylic sealant or polyurethane sealant as provided for by JIS A 5758 shall be used.
  - (8) In case glass wool or rock wool is used for thermal insulation, glass wool shall be used for specimens.
  - (9) When there are two or more kinds of roofing materials to be applied on sheathing roof boards, the heaviest one shall be used for specimens.
  - (10) When there are two or more types of corrugated roofing sheets in terms of sectional dimension, the one with the lowest crown and the greatest crown-to-crown distance shall be used as a specimen.
  - (11) For materials used as roof waterproofing, the one containing the greatest volume of organic compounds shall be chosen for a specimen.
  - (12) Specimens shall be kept in the air-dry condition. The definition of “air-dry condition” used herein is the condition of a wooden component material having a water content of 15% or under, of a material that contains crystalline water, such as gypsum, having a

water content of 2% or under when it is dried at 40°C until its weight becomes constant, and of other materials having a water content of 5% or under. However, this condition shall not be applied to cases where such as equilibrium is confirmed to be established in a room that the water content therein is kept almost constant.

### 3. Test Equipment

- (1) The furnace shall be capable to reproduce the standard temperature curve that is specified in 4 herein almost uniform over the entire test surface.
- (2) The furnace shall be capable of heating one side of a wall specimen, the bottom side of a floor or roof specimen, three sides of a beam specimen except for the top side, and all sides of a stairs specimen which are considered to simultaneously receive the heat of a fire.
- (3) Hot junctions of thermocouples used to measure the heating temperature (herein “in-furnace thermocouples”) shall be uniformly distributed on the test surface, and a minimum of 9 shall be installed on a wall, a minimum of 8 on a floor, a minimum of 6 on a roof, a minimum of 8 on a beam, and a minimum of 4 on a stair. They shall be placed 100 mm away from the specimen.
- (4) The test equipment shall have a weight or a force application device that can reproduce the weight as specified in (2) and (3) of 4.
- (5) The furnace shall be equipped with a device to measure in-furnace pressure.

### 4. Test Conditions

- (1) A specimen shall be so heated that the temperature measured by an in-furnace thermocouple (herein “heating temperature”) will be expressed, with tolerances, by the following formula:

$$T = 345 \log_{10} (8t + 1) + 20,$$

where T is the average heating temperature (°C) and t is the time (min.).

The allowable deviation for the heating temperature,  $d_e$ , shall take the following value except for specimens that contain a large volume of flammable material and for which a sudden firing of the flammable material is explicitly confirmed to have increased the average in-furnace temperature.

- a)  $5 < t \leq 10$        $de \leq 15$  (%)
- b)  $10 < t \leq 30$        $de = \{15 - 0.5 (t - 10)\}$  (%)
- c)  $30 < t \leq 60$        $de = \{5 - 0.083 (t - 30)\}$  (%)
- d)  $60 < t$                $de = 2.5$  (%)

$$de = 100 (A - A_s) / A_s$$

where A is the area under the actual average heating temperature/time curve;  $A_s$  is the area under the standard temperature/time curve; and t is the time (min.).

The area shall be calculated by accumulating the values at an interval shorter than 1 min. for a) and shorter than 5 min. for b), c), and d).

- (2) In the case of construction that normally supports a vertical load, the test shall be conducted while a load is applied so that it will cause a degree of stress equivalent to the allowable unit stress for sustained loads on the section of the principal parts necessary for structural strength of the specimen. Provided that, in the case of floors of which room has a specific use, the floor shall be tested with live loads as specified by Article 85 of the Order, applied as appropriate according to that use.
- (3) For roofs that will not bear live loads, the roof shall be demarcated into sections of  $1 \text{ m}^2$  or less, and a concentrated load of 65 kg shall be applied to the center of each of these sections. For stairs, the concentrate load of 65 kg shall be applied to the center of the treadboard of stairs.
- (4) Among types of construction that normally supports a vertical load, those that uses steel for the principal parts necessary for structurally strength may be heated in the test without loading.
- (5) In case the fulcrum-to-fulcrum distance for an actual floor and roof exceeds the testable maximum fulcrum-to-fulcrum distance, a load that is generally supported by the actual fulcrum-to-fulcrum distance shall be applied to the specimen.
- (6) In the case of floors and roofs using continuous beams, the actual type of construction and actual loading conditions shall be reproduced for testing.
- (7) The specimen shall be heated for the duration equal to the time as stipulated in Article 107 of the Order (Duration of heat produced during a normal fire) (herein “required fireproof rating”) and left for a duration three times the required fireproof rating without

heating while measurements as laid down in 5 herein shall be continuously made during that shelf time. Provided that, in case the material used for a structural component is quasi-noncombustible, the specimen may be heated for the duration 1.2 times the required fireproof rating and, during that time, measurements specified in 5 shall be continuously made.

- (8) The pressure difference shall be applied on the surface of the test specimen as laid down in a) to d) below:
  - a) Pressure gradient in the vertical direction in the heating furnace shall be 8 Pa for a height of 1,000 mm on the average.
  - b) The deviation of pressure applied on the test surface shall be adjusted so that it will be  $\pm 5$  Pa from the beginning of the test to the elapse of 5 minutes and  $\pm 3$  Pa from the beginning of the test to the elapse of 10 minutes.
  - c) Pressure on the test surface of a vertical member shall have a gradient of 0 at a height of 500 mm from the bottom of the specimen. Provided that the neutral axial height shall be adjusted so as not to exceed 20 Pa at the upper end of the specimen.
  - d) Pressure on the test surface of a horizontal member shall be 20 Pa positive at a height of 100 mm from the bottom surface of the specimen.

## 5. Measurements

- (1) Temperature, contraction, and deflection shall be measured once every less than a minute.
- (2) In case the specimen of a construction that normally supports a vertical load is tested with loads on, the value of contraction in the axial direction and the rate of contraction in the axial direction shall be measured for walls and the value of deflection and the rate of deflection for floors, roofs, beams, and stairs.
- (3) When the specimen of a construction that normally supports a vertical load is tested without loads on, thermocouples shall be uniformly installed over the steel surface important in terms of structural strength and the temperature of the steel material measured. The number of thermo-junctions to measure steel temperature shall be a minimum of 5 for walls, floors, and roofs, and a minimum of 15 for beams. In the case of columns that incorporate base-isolation materials, if the column member excluding the base-isolation materials is deemed to be a fireproof structure,

thermocouples shall be placed evenly on the surface of the laminated rubber base-isolation materials to allow measurement of the surface temperature of the laminated rubber base-isolation materials. The number of thermo-junctions for the thermocouples used to measure the surface temperature of the base-isolation materials shall be at least 12.

- (4) Temperature on the rear surface of walls and floors shall be measured in compliance with the following rules of a) to c):
  - a) Rear surface temperature shall be measured by fixed thermocouples and movable thermocouples.
  - b) Thermo-junctions of the fixed thermocouples shall be uniformly installed in a minimum of five on the non-heated surface.
  - c) Rear surface temperature shall be measured by fixed thermocouples once every less than a minute. Movable thermocouples shall be immediately applied to any location whose temperature is supposed to be high.
- (5) Non-heated surfaces shall be visually observed to check for the generation of flames or the presence of cracks through which flames could permeate. The term “crack through which flames could permeate” used in this document is a crack through which flames move up onto the non-heated surface or through which the inside of the heating furnace is seen.
- (6) In the case of those mesh rebars used in ALC panels, PC panels, and other molded panels which measure 3 mm or more in diameter, the requirement of steel material measurement shall apply to them.

## 6. Judgment

If a specimen satisfies the following criteria as the result of the test, the material shall be judged acceptable.

- (1) In the case of a specimen of the construction normally supports a vertical load and which was given the loading test, the specimen shall satisfy all of the following conditions, a) to c), until the end of the test (which is equivalent to three times the required fireproof rating since the completion of heating for a duration equal to the required fireproof rating or to 1.2 times the required fireproof rating since the beginning of the test).

- a) Maximum value of contraction and maximum rate of contraction, both in the axial direction, of a wall and column specimens shall be:

Maximum value of contraction in the axial direction (mm):  $h/100$

Maximum rate of contraction in the axial direction (mm/min.):  $3 h/1,000$

where h is the initial height of the specimen (mm).

- b) Maximum value of deflection and maximum rate of deflection shall take the following value for floors, roofs, and beams, provided that maximum rate of deflection will not be applied until the deflection exceeds  $L/30$ :

Maximum value of deflection (mm):  $L^2/400 d$

Maximum rate of deflection (mm/min.):  $L^2/9000 d$

where L is the clear span of the specimen (mm); and d is the distance from the extreme compressed fiber to the extreme tension fiber of the structural cross-section of the specimen(mm).

- c) Maximum value of deflection of the treadboard shall not exceed  $1/30$  of the support length for stairs.

- (2) In the case of a specimen which is of construction that normally supports a vertical load and for which steel temperature was measured without loading, the maximum or average value of the steel temperature measured shall not exceed the value that corresponds to each part or construction of the building, as shown in the following table:

Type of construction and class of temperature		Part of the building	
		Beam (°C)	Floor, roof, and wall (excluding non-bearing wall) (°C)
Reinforced concrete, reinforced concrete panel, etc.	Maximum temperature	500	550
Prestressed concrete	Maximum temperature	400	450
Steel Light-gauge sheet shapes	Maximum temperature	450	500
	Average temperature	350	400

When the surface temperature of base-isolation materials is measured, the maximum surface temperature at the end of the test must not exceed the assured performance temperature. The assured performance temperature is defined as the temperature at which it has been clearly and separately determined by means of JIS K 6254 or an equivalent compressive strength test, etc., that there will be no decline in performance.

- (3) In the case of walls (excluding cases where the external wall is heated from indoors) and floors, a one-hour heating test (or 30 minutes for non-bearing external wall in the portions other than those liable to catch fire) shall be conducted and the rear side temperature of the specimen shall be kept at 140 K or under for the average and 180 K or under for the maximum until three hours (or 1.5 hours for non-bearing external wall in the portions other than those liable to catch fire) passed since the end of heating.
- (4) In the case of walls and floors whose structurally important materials are quasi-noncombustible (excluding cases where the external wall is heated from indoors), a 72 minute heating test shall be conducted (or 36 minutes for non-bearing external wall in the portions other than those liable to catch fire) and during this heating the rear side temperature of the specimen shall be kept a 140 K or under for the average and 180 K or under for the maximum.
- (5) In the case of walls and floors, a one-hour heating test shall be conducted (or 30 minutes for non-bearing external wall in the portions other than those liable to catch fire), and the specimen shall satisfy the following criteria until three hours (or 1.5 hours for non-bearing wall in the portions other than those liable to catch fire) passed since the end of heating:
  - a) There shall be no spurting of flames that continuously spreads to the non-heated side for over 10 seconds.
  - b) There shall be no flame that continuously exists at the non-heated surface for over 10 seconds.

- c) There shall be no cracking or other damage that could be used for a passage of flames.
- (6) In the case of walls and floors whose structurally important materials are quasi-noncombustible, a 72 minute heating test (or 36 minutes for non-bearing external wall in the portions other than those liable to catch fire) shall be conducted and, during that heating, the specimen shall satisfy the following criteria:
- a) There shall be no spurting of flame that continuously exists to the non-heated side for over 10 seconds.
  - b) There shall be no flame that continuously exists at the non-heated surface for over 10 seconds.
  - c) There shall be no cracking or other damage that could be used for a passage of flames.
- (7) In the case of roofs, a 30 minute heating test shall be conducted and the specimen shall satisfy the following criteria until 1.5 hours passed since the end of the heating test:
- a) There shall be no spurting of flame that continuously exists to the non-heated side for over 10 seconds.
  - b) There shall be no flame that continuously exists at the non-heated surface for over 10 seconds.
  - c) There shall be no cracking or other damage that could be used for a passage of flames.
- (8) In the case of roofs whose structurally important materials are quasi-noncombustible, a 36 minutes heating test shall be conducted and, during that heating, the specimen shall satisfy the following criteria:
- a) There shall be no spurting of flame that continuously exists to the non-heated side for over 10 seconds.
  - b) There shall be no flame that continuously exists at the non-heated surface for over 10 seconds.
  - c) There shall be no cracking or other damage that could be used for a passage of flames.

## 4.2 Quasi-fireproof performance test and evaluation method

Performance evaluation required by Clause 7-2, Article 2, Law (Quasi-fireproof Construction) and Clause 2-2-1-1, Article 115, Order (Major Construction Components of Special Buildings Requiring No Fireproof Building) shall be conducted by the following test and evaluation procedure:

### 1. General

- (1) Quasi-fireproof performance test shall be conducted on a set of specimen specified in 2. and measured as specified in 5 by using the test equipment as specified in 3. under the test condition specified in 4. If the measurement result satisfies the judgment criteria specified in 6, the specimen shall be judged as classified.
- (2) Quasi-fireproof performance test shall be given to each side of the component which is confirmed to be simultaneously exposed to the heat of fire. This rule shall not be applied to some types of wall as an exception if any exposure side of the wall is clearly certified to be as fireproof as or more fireproof than other sides by the quasi-fireproof performance test separately conducted by a certified performance evaluation institute. In this case, the quasi-fireproof performance test may be omitted for that side of the wall.

### 2. Specimen

- (1) A composition and material of the specimen shall be representing the actual product system. Providing that the actual component has two or more variations with different specifications, either a) or b) in the following shall apply:
  - a) In case there are two or more types of sectional loss caused by grooving or other surface treatment given onto the surface of the fire preventive cladding, the type that has the largest total volume of lack shall be used as a specimen.
  - b) In case there are two or more types of composition or configuration for the surface of the fire preventive cladding, the type that has the greatest mass of organic compound shall be used as a specimen.
- (2) Dimensions, composition, and specific gravity of a specimen shall be within the controllable range.

- (3) For the number of specimens, there shall be two for each surface to be heated, as provided for in (2) of 3. herein, unless otherwise specified. The exception is walls with a symmetrical section, for which the test to either side may be omitted.
- (4) The form and size of a specimen shall be representing that of the actual component except in cases where testing with a specimen sized identical to the actual component is extremely difficult. In such cases, the shape and size of a specimen may be changed providing that the shape of a specimen and the area to be heated may be either a) to g) as specified in the following or that the fire preventive performance of the specimen shall be kept the same by maintaining the original material and composition, the original fire preventive cladding application intervals, or the original spacing of studs or furring strips.
- a) For walls, the specimen shall be a rectangular panel measuring a minimum of 3,000 mm in width, a minimum of 3,000 mm in height, and as thick as the actual product system.
  - b) For floors (excluding cases where the upper surface of the floor is heated) and roofs, the specimen shall be a rectangular panel and measures a minimum of 4,000 mm in the longer side, a minimum of 3,000 mm in the shorter side (or a minimum of 2,000 mm if the specimen is only supported at the shorter side), and as thick as the actual component system.
  - c) For beams, the form and size of section of the specimen shall be representing that of the actual component system, while the length shall be a minimum of 4,000 mm.
  - d) For planciers, the shape of both ends of the eaves and the projection of the eaves shall be representing that of the actual component system, and its width shall be 1,800 mm or more, and a fiber-mixed calcium silicate panel of 8 mm in thickness and  $900 \pm 100 \text{ kg/m}^3$  in density (herein “standard panel”) shall be attached to the portion facing the roof space. The standard dimension of a plancier specimen shall be 1,800 mm in width, 500 mm in eaves projection, and 1,800 mm in the height of the plancier from the bottom surface of the specimen.
  - e) For stairs, the shape and size of a treadboard and the sectional shape and size of a beam supporting treadboards shall be representing that of the actual component system. The width shall be a minimum of 1,200 mm and the number of steps shall be a minimum of 5.

- f) For the top surface of floors, the specimen shall be a rectangular panel measuring a minimum of 2,000 mm in longer side and a minimum of 1,800 mm in shorter side and as thick as the actual component.
- (5) External wall and partition wall specimens, which are prepared for each construction method and have the following specifications shall be called standard ones (herein “standard specimens”).
- a) Stud used for the frame wall method  
Sectional size 38 × 89 mm
  - b) Column used for wooden framework construction  
Sectional size 105 × 105 mm
  - c) Column used for light-weight steelframe construction  
C-75 × 45 × 15 × 1.6 mm
  - d) Exterior cladding for external walls shall be applied laterally.
  - e) For the indoor side cladding for external walls, specimens for a 30 min. fireproof specification shall have a single-ply gypsum board (12.5 mm thick) as specified by the Ministry of Construction Notification No. 1358, 2000, (herein “Notification No. 1358”), and those for a 45 min. fireproof specification shall have double-play gypsum board (12.5 mm thick lower ply and 9.5 mm thick upper ply). For the indoor side cladding for a 60 min. fireproof external wall, specimens shall have double-ply gypsum board (12.5 mm thick) as provided for by the Ministry of Construction Notification No. 1380, 2000, (herein “Notification No. 1380”).
- (6) Floor specimens prepared for each construction method shall be called standard specimens when they satisfy the following specifications:
- a) Joist used for frame construction  
Sectional size 38 × 235 mm
  - b) Joist used for wooden framework construction  
Sectional size 45 × 45 mm

- c) In case the test surface is the rear side of the floor (the undersurface or the ceiling surface, herein the “undersurface”), the material to be applied to the top surface of the floor shall be a structural veneer (12 mm thick) and a single-ply gypsum board (9.5 mm thick) for a 45 min. fireproof specification as specified by Notification No. 1358. The material to be applied to the top surface of a 60 min. fireproof floor shall be a structural veneer (12 mm thick) and a single-ply gypsum board (12.5 mm thick) as specified by Notification No. 1380.

In case the test surface is the top surface of a floor, the material to be applied to the undersurface of the floor shall be a single-ply reinforced gypsum board (15 mm thick) for a 45 min. fireproof specification as stipulated by Notification No. 1358. The material to be applied to the undersurface of a 60 min. fireproof floor shall be a double-ply reinforced gypsum board (12.5 mm thick) as stipulated by Notification No. 1380.

- (7) A standard plancier specimen shall be of wooden framework construction, with a standard panel applied to the part facing the roof space. The exterior side cladding for a wall shall be double-ply fiber-mixed calcium silicate board (25 mm thick) and the indoor side cladding shall be single-ply gypsum board (12.5 mm thick). The eaves roof shall have a pitch of 3/10 and be roofed by double fiber-mixed calcium silicate board (25 mm thick). Fascia boards shall be double fiber-mixed calcium silicate board (25 mm thick) applied over the wood groundwork (130 × 30 mm). For the type of wood used for a standard specimen, Oregon pine shall be used for columns, while Oregon pine or Western hemlock for other components.
- (8) For the fixing interval of fire preventive cladding for a specimen, the largest interval among those actually used shall be chosen.
- (9) In cases where weak points, such as joints, from the viewpoint of fire preventive performance may appear when building construction is actually executed using these parts, the weak points shall be placed in the middle of the specimen. Application of fire preventive cladding shall be so arranged as to include as many weak points, such as joints, as possible within the effective heated area. For joints of a specimen to be tested for tiling or other setting performance, straight joints with continuous straight joints both in the vertical and horizontal direction shall be used.
- (10) In case no sealant is specified for use in joints of fire preventive cladding, acrylic sealant or polyurethane sealant as provided for by JIS A 5758 shall be used.

- (11) In case glass wool or rock wool is used for thermal insulant, glass wool shall be used for specimens.
- (12) When there are two or more kinds of roofing materials to be applied on roofing boards, the heaviest kind shall be used for specimens.
- (13) When there are two or more types of corrugated roofing sheets in terms of sectional dimension, the one with the lowest crown and the greatest crown-to-crown distance shall be used as a specimen.
- (14) For materials used as roof waterproofing, the one containing the greatest volume of organic compounds shall be chosen for a specimen.
- (15) Specimens shall be kept in the air-dry condition. The definition of “air-dry condition” used herein is the condition of a wooden component material having a water content of 15% or under, of a material that contains crystalline water, such as gypsum, having a water content of 2% or under when it is dried at 40°C until its weight becomes constant, and of other materials having a water content of 5% or under. However, this condition shall not be applied to cases where such an equilibrium is confirmed to be established in a room that the water content therein is kept almost constant.

### 3. Test Equipment

- (1) The test equipment shall be the equipment capable of applying temperatures that change with time as specified by 4. herein almost evenly over the entire test surface.
- (2) The heating furnace shall be the furnace capable of heating one side of a wall specimen, the bottom side of a floor or roof specimen, three sides of a beam specimen except for the top side, and all sides of a stairs specimen confirmed to simultaneously receive the heat of a fire.
- (3) Hot junctions of a thermocouple used to measure the heating temperature (herein “in-furnace thermocouple”) shall be uniformly distributed over the test surface, and a minimum of 9 shall be installed on walls, a minimum of 8 on floors, a minimum of 6 on roofs, a minimum of 12 on beams, a minimum of 8 on beams, a minimum of 3 on planciers and a minimum of 4 on stairs. They shall be placed 100 mm away from the specimen.
- (4) The test equipment shall have a weight or a force application device that can reproduce the weight as specified by (2) and (3) of 4.

- (5) The heating furnace shall be equipped with a device to measure in-furnace pressure.

#### 4. Test Conditions

- (1) A specimen shall be so heated that the temperature measured by an in-furnace thermocouple (herein “heating temperature”) will take the value, within the allowable range, as calculated by the following equation:

$$T = 345 \log_{10} (8t + 1) + 20,$$

where T is average in-furnace temperature (°C) and t is the lapse of time (min.) since the beginning of the test.

The allowable error for the heating temperature,  $de$ , shall take the following value except for specimens that contain a large volume of flammable material and for which a sudden firing of the flammable material is explicitly confirmed to have increased the average in-furnace temperature.

- a)  $5 < t \leq 10$       $de \leq 15$  (%)  
b)  $10 < t \leq 30$       $de = \{15 - 0.5 (t - 10)\}$  (%)  
c)  $30 < t \leq 60$       $de = \{5 - 0.083 (t - 30)\}$  (%)

$$de = 100 (A - As) / As$$

where A is the area under the actual average in-furnace temperature’s time curve;  $As$  is the area under the standard temperature time curve; and t is the lapse of time (min.) since the beginning of the test.

The area shall be calculated by accumulating the values at an interval shorter than 1 min. for a) and shorter than 5 min. for b) and c).

- (2) In the case of construction that supports a stationary vertical load, the test shall be conducted while a load is applied so that it will cause a degree of stress equivalent to the long-term allowable unit stress for sustained loads on the section of the principal parts necessary for structural strength of the specimen. Provided that, in the case of floors of which room has a specific use, the floor shall be tested with live loads as specified by Article 85 of the Order applied as appropriate according to that use.

- (3) For roofs that will not be used as a rooftop, the roof shall be demarcated into sections of 1 m<sup>2</sup> or less, and a concentrated load of 65 kg shall be applied to the center of each of these sections or to the center of the treadboard of stairs.
- (4) In case the fulcrum-to-fulcrum distance for an actual floor and roof exceeds the testable maximum fulcrum-to-fulcrum distance, a load that is generally supported by the actual fulcrum-to-fulcrum distance shall be applied to the specimen.
- (5) In the case of floors and roofs built by the continuous girder method, that actual type of construction and loading conditions shall be reproduced before testing.
- (6) Measurement as specified by 5. shall be made while a specimen is heated for the “time for which the heat of fire is applied” as laid down by the Order (herein the “required fireproof rating”).
- (7) The pressure difference shall be applied on the surface of test specimen as laid down in a) to d) below:
  - a) Pressure gradient in the vertical direction in the heating furnace shall be 8 Pa for a height of 1,000 mm on the average.
  - b) The error of pressure applied on the test surface shall be adjusted so that it will be  $\pm 5$  Pa from the beginning of the test to the elapse of 5 minutes and  $\pm 3$  Pa from the beginning of the test to the elapse of 10 minutes.
  - c) Pressure on the test surface of a vertical member shall have a gradient of 0 at a height of 500 mm from the bottom of the specimen. Provided that the neutral axial height shall be adjusted so as not to exceed 20 Pa at the upper end of the specimen.
  - d) Pressure on the test surface of a horizontal member shall be 20 Pa positive at a height of 100 mm from the bottom surface of the specimen. However, it does not apply when heating the surface of the floor.

## 5. Measurement

- (1) Temperature, contraction, and deflection shall be measured once every less than a minute.
- (2) In case the specimen of a construction that supports a stationary vertical load is tested with loads on, the value of contraction in the axial direction and the rate of contraction

in the axial direction shall be measured for walls and the value of deflection and the rate of deflection for floors (excluding cases where the top surface of a floor is heated), roofs, beams, and stairs.

- (3) Temperature on the rear surface of walls and floors shall be measured in compliance with the following rules of a) to c):
  - a) Rear surface temperature shall be measured by fixed thermocouples and movable thermocouples.
  - b) Hot junctions of the fixed thermocouples shall be uniformly installed in a minimum of five on the non-heated surface (or a minimum of three on the non-heated surface of a standard panel for planciers).
  - c) Rear surface temperature shall be measured by fixed thermocouples once every less than a minute. For movable thermocouples, in case there occurs any part supposed to be heated to a very high temperature, that part shall be immediately measured.
- (4) Non-heated surfaces shall be visually observed to check for the generation of flame or the presence of cracks through which flames could permeate. The term “crack through which flames could permeate” used in this document is a crack through which flames move up onto the non-heated surface or through which the inside of the heating furnace is seen.

## 6. Judgment

If a specimen satisfies the following criteria as the result of the test, the material shall be judged acceptable.

- (1) In the case of a specimen whose construction supports a stationary vertical load and which was given the loading test, the specimen shall satisfy all of the following conditions, or a) to c), until the end of the test (which is the end of heating for a duration equal to the required fireproof rating).
  - a) Maximum value of contraction and maximum rate of contraction, both in the axial direction, of a wall specimen shall be:

Maximum value of contraction in the axial direction (mm):  $h/100$

Maximum rate of contraction in the axial direction (mm/min.):  $3 h/1,000$

where h is the initial height of the specimen (mm).

- b) Maximum value of deflection and maximum rate of deflection shall take the following value for floors (excluding cases where the top surface of a floor is heated), roofs, and beams, provided that maximum rate of deflection will not be applied until the deflection exceeds L/30:

Maximum value of deflection (mm):	$L^2/400 d$
Maximum rate of deflection (mm/min.):	$L^2/9000 d$

where L is the fulcrum-to-fulcrum distance (mm) of the specimen; and d is the distance from the compressed edge of the structural section of the specimen to the tensile edge (mm).

- c) Maximum value of deflection of the treadboard shall not exceed 1/30 of the support length for stairs.
- (2) In the case of walls (excluding cases where the external wall is heated from indoors) and floors, the rear side temperature of the specimen shall be kept at 140 K or under for the average and 180 K or under for the maximum during a heating test.
- (3) In the case of walls, floors, and roofs, the following criteria shall be satisfied during a heating test:
- a) There shall be no spurting of flame that continuously exists to the non-heated side for over 10 seconds.
  - b) There shall be no flame that continuously exists at the non-heated surface for over 10 seconds.
  - c) There shall be no cracking or other damage that could be used for a passage of flames.
- (4) In the case of planciers (excluding cases where the plancier is separated from the roof space or ceiling plenum by the external wall in an effective way in terms of fireproof performance), the following criteria shall be satisfied during a heating test:
- a) There shall be no spurting of flame that continuously exists to the non-heated side of the standard panel for over 10 seconds.
  - b) There shall be no flame that continuously exists at the non-heated surface of the standard panel for over 10 seconds.

- c) There shall be no cracking or other damage in the standard panel that could be used for a passage of flames.

### 4.3 Fire preventive performance test and evaluation procedure

Performance evaluation required by Clause 8, Article 2, Law (Fire Preventive Construction) shall be conducted by the following test and evaluation procedures:

#### 1. General

Fire preventive performance test shall be conducted on a set of specimen specified in 2 and measured as specified in 5 by using the test equipment specified in 3. under the test condition as specified in 4. If the measurement result satisfies the judgment criteria specified in 6, the specimen shall be judged as classified.

#### 2. Specimen

- (1) The composition and the material of the specimen shall be representing the actual product system. Providing that the actual component has two or more variations with different specifications, either a) or b) in the following shall apply:
  - a) In case there are two or more types of sectional lack caused by grooving or other surface treatment given onto the surface of the fire preventive cladding, the type that has the largest total volume of lack shall be used as a specimen.
  - b) In case there are two or more types of composition or configuration for the surface of the fire preventive cladding, the type that has the greatest mass of organic compound shall be used as a specimen.
- (2) Dimensions, composition, and density of a specimen shall be within the allowable range.
- (3) The number of specimens shall be two for each surface to be heated, as provided for in (2) of 3. herein.
- (4) The form and size of a specimen shall be representing that of the actual product system except in cases where testing with a specimen sized identical to the actual one is extremely difficult. In such cases, the shape and size of a specimen may be changed providing that the shape of a specimen and the area to be heated may be either a) or b) as specified in the following or that the fire preventive performance of the specimen shall be kept the same by maintaining the original material and composition, the original fire preventive cladding application intervals, or the original spacing of studs or furring strips.

- a) For external walls, the specimen shall be a rectangular panel measuring a minimum of 3,000 mm in width, a minimum of 3,000 mm in height, and as thick as the actual product system.
  - b) For planciers, the shape of both ends of the eaves and the projection of the eaves shall be identical to that of the actual component, and its width shall be 1,800 mm or more, and a fiber-mixed calcium silicate panel of 8 mm in thickness and  $900 \pm 100 \text{ kg/m}^3$  in density (herein “standard panel”) shall be attached to the portion facing the roof space. The standard dimension of a plancier specimen shall be 1,800 mm in width, 500 mm in eaves projection, and 1,800 mm in the height of the plancier from the bottom surface of the specimen.
- (5) External wall and partition wall specimens, which are prepared for each construction method and have the following specifications shall be standard ones (herein “standard specimens”).
- a) Stud used for the frame wall method  
Sectional size 38 mm × 89 mm
  - b) Column used for wooden framework construction  
Sectional size 105 mm × 105 mm
  - c) Column used for light-weight steelframe construction  
C-75 × 45 × 15 × 1.6 mm
  - d) Exterior cladding for external walls shall be applied laterally.
- (6) A standard specimen for plancier shall be of wooden framework construction, with a standard panel applied to the part facing the roof space. The exterior cladding for a wall shall be double-ply fiber-mixed calcium silicate board (25 mm thick) and the interior cladding shall be single-ply gypsum board (12.5 mm thick). The eaves roof shall have a pitch of 3/10 and be roofed by double fiber-mixed calcium silicate board (25 mm thick). Fascia boards shall be double fiber-mixed calcium silicate board (25 mm thick) applied over the wood groundwork (130 × 30 mm). For the type of wood used for a standard specimen, Oregon pine shall be used for columns, while Oregon pine or Western hemlock for other components.
- (7) For the fixing interval of fire preventive cladding for a specimen, the largest interval among those actually used shall be chosen.

- (8) In cases where weak points, such as joints, from the viewpoint of fire preventive performance may appear when building construction is actually executed using these parts, the weak points shall be placed in the middle of the specimen. Application of fire preventive cladding shall be so arranged as to include as many weak points, such as joints, as possible within the effective heated area. For joints of a specimen to be tested for tiling or other setting performance, straight joints with continuous straight joints both in the vertical and horizontal direction shall be used.
- (9) In case no sealant is specified for use in joints of fire preventive cladding, acrylic sealant or polyurethane sealant as provided for by JIS A 5758 shall be used.
- (10) In case glass wool or rock wool is used for thermal insulation, glass wool shall be used for specimens.
- (11) Specimens shall be kept in the air-dry condition. The definition of “air-dry condition” used herein is the condition of a wooden component material having a water content of 15% or under, of a material that contains crystalline water, such as gypsum, having a water content of 2% or under when it is dried at 40°C until its weight becomes constant, and of other materials having a water content of 5% or under. However, this condition shall not be applied to cases where such as equilibrium is confirmed to be established in a room that the water content therein is kept almost constant.

### 3. Test Equipment

- (1) The furnace shall be capable to reproduce standard temperature curve specified in 4 almost uniform over the entire test surface.
- (2) The furnace shall be capable of heating one side of a wall specimen and the bottom side of a plancier specimen.
- (3) Hot junctions of thermocouples used to measure the heating temperature (herein “in-furnace thermocouple”) shall be uniformly distributed over the test surface, and a minimum of 9 shall be installed on a wall and a minimum of 3 on a plancier. They shall be placed 100 mm away from the specimen.
- (4) The test equipment shall have a weight or a force application device that can reproduce the weight as specified by (2) of 4.
- (5) The heating furnace shall be equipped with a device to measure in-furnace pressure.

#### 4. Test Conditions

- (1) A specimen shall be so heated that the temperature measured by an in-furnace thermocouple (herein “heating temperature”) will take the value, within the allowable range, as calculated by the following equation:

$$T = 345 \log_{10} (8t + 1) + 20,$$

where T is average heating temperature (°C) and t is the lapse of time (min.) since the beginning of the test.

The allowable error for the heating temperature,  $de$ , shall take the following value except for specimens that contain a large volume of flammable material and for which a sudden firing of the flammable material is explicitly confirmed to have increased the average in-furnace temperature.

- a)  $5 < t \leq 10$       $de \leq 15$  (%)  
b)  $10 < t \leq 30$       $de = \{15 - 0.5 (t - 10)\}$  (%)

$$de = 100 (A - A_s)/A_s$$

where A is the area under the actual average heating temperature’s time curve;  $A_s$  is the area under the standard temperature time curve; and t is the lapse of time (min.) since the beginning of the test.

The area shall be calculated by accumulating the values at an interval shorter than 1 min. for a) and shorter than 5 min. for b).

- (2) In the case of construction that supports a stationary vertical load, the test shall be conducted while a load is applied so that it will cause a degree of stress equivalent to the long-term allowable unit stress for sustained loads on the section of the principal parts necessary for structural strength of the specimen.
- (3) The specimen shall be heated for the duration of 30 minutes.
- (4) The pressure difference shall be applied on the surface of the test specimen as laid down in a) to d) below:
- a) Pressure gradient in the vertical direction in the heating furnace shall be 8 Pa for a height of 1,000 mm on the average.

- b) The error of pressure applied on the test surface shall be adjusted so that it will be  $\pm 5$  Pa from the beginning of the test to the elapse of 5 minutes and  $\pm 3$  Pa from the beginning of the test to the elapse of 10 minutes.
- c) Pressure on the test surface of a vertical member shall have a gradient of 0 at a height of 500 mm from the bottom of the specimen. Provided that the neutral axial height shall be adjusted so as not to exceed 20 Pa at the upper end of the specimen.
- d) Pressure on the test surface of a plancier shall be 20 Pa positive at a height of 100 mm from the bottom surface of the specimen.

## 5. Measurement

- (1) Temperature and contraction shall be measured once every less than a minute.
- (2) In case the specimen of a construction that supports a stationary vertical load is tested with loads on, the value of contraction and the rate of contraction, both in the axial direction, shall be measured.
- (3) Temperature on the rear surface shall be measured in compliance with the following rules of a) to c):
  - a) Rear surface temperature shall be measured by fixed thermocouples and movable thermocouples.
  - b) Hot junctions of the fixed thermocouples shall be uniformly installed in a minimum of five on the surface opposite to the heated surface (or a minimum of three on the non-heated surface of a standard panel for planciers).
  - c) Rear surface temperature shall be measured by fixed thermocouples once every less than a minute. Movable thermocouples shall be immediately applied to any location whose temperature is supposed to be high.
- (4) Non-heated surfaces shall be visually observed to check for the generation of flame or the presence of cracks through which flames could permeate. The term “crack through which flames could permeate” used in this document is a crack through which flames move up onto the non-heated surface or through which the inside of the heating furnace is seen.

## 6. Judgment

If a specimen satisfies the following criteria as the result of the test, the material shall be judged acceptable.

- (1) In the case of an external wall that supports a stationary vertical load, the Maximum value of contraction in the axial direction and Maximum rate of contraction in the axial direction shall be equal to or smaller than the following during the period from the beginning of the test to the elapse of 30 minutes:

Maximum value of contraction in the axial direction (mm):  $h/100$

Maximum rate of contraction in the axial direction (mm/min.):  $3 h/1,000$

where h is the initial height of the specimen (mm).

- (2) The rear surface temperature of an external wall specimen and the rear surface temperature of a standard panel of a plancier specimen shall be 140 K or under in the average or 180 K or under at maximum during the period from the beginning of the test to the elapse of 30 minutes.
- (3) An external wall specimen shall satisfy the following criteria during the period from the beginning of the test to the elapse of 30 minutes:
  - a) There shall be no spurting of flames that continuously spread to the non-heated side for over 10 seconds.
  - b) There shall be no flames that continuously exist at the non-heated surface for over 10 seconds.
  - c) There shall be no cracking or other damage that could be used for a passage of flames.
- (4) In the case of planciers (excluding cases where the plancier is separated from the roof space or ceiling plenum by the external wall, the following criteria shall be satisfied during a heating test:
  - a) There shall be no spurting of flames that continuously spread to the non-heated side of the standard panel for over 10 seconds.
  - b) There shall be no flames that continuously exist at the non-heated surface of the standard panel for over 10 seconds.
  - c) There shall be no cracking or other damage in the standard panel that could be used for a passage of flames.

#### 4.4 Quasi-fire preventive performance test and evaluation procedure

Performance evaluation required by Article 23, Law (External Wall of Quasi-Fire Preventive Performance) shall be conducted by the following test and evaluation procedure:

##### 1. General

Quasi-fire preventive performance test shall be conducted on a set of specimen specified in 2. and measured as specified in 5. using the test equipment specified in 3. under the test condition specified in 4. If the measurement result satisfies the judgment criteria specified in 6. the specimen shall be judged as classified.

##### 2. Specimen

- (1) The composition and the material of the specimen shall be representing the actual product system. Providing that the actual component has two or more variations with different specifications, either a) or b) in the following shall apply:
  - a) In case there are two or more types of sectional lack caused by grooving or other surface treatment given onto the surface of the fire preventive cladding, the type that has the largest total volume of lack shall be used as a specimen.
  - b) In case there are two or more types of composition or configuration for the surface of the fire preventive cladding, the type that has the greatest mass of organic compound shall be used as a specimen.
- (2) Dimensions, composition, and density of a specimen shall be within the allowable range.
- (3) The number of specimen shall be two.
- (4) The form and size of a specimen shall be identical to that of the actual product system except in cases where testing with a specimen sized identical to the actual product system is extremely difficult. In such cases, the form and size of a specimen may be changed providing that the fire-preventive performance of the specimen shall be kept the same by setting the width and height of the area to be heated to a minimum of 3,000 mm or by maintaining the original material and composition, the original fire preventive cladding application intervals, or the original spacing of studs or furring strips.

- (5) Specimens which are prepared for each construction method and have the following specifications shall be standard ones (herein “standard specimens”):
- a) Stud used for the frame wall method  
Sectional size 38 × 89 mm
  - b) Column used for wooden framework construction  
Sectional size 105 × 105 mm
  - c) Exterior cladding for external walls shall be applied laterally.
- (6) For the fixing interval of fire preventive cladding for a specimen, the largest interval among those actually used shall be chosen.
- (7) In cases where weak points, such as joints, from the viewpoint of fireproof performance may appear when building construction is actually executed using these parts, the weak points shall be placed in the middle of the specimen. Application of fire preventive cladding shall be so arranged as to include as many weak points, such as joints, as possible within the effective heated area. For joints of a specimen to be tested for tiling or other setting performance, straight joints with continuous straight joints both in the vertical and horizontal direction shall be used.
- (8) In case no sealant is specified for use in joints of fire preventive cladding, acrylic sealant or polyurethane sealant as provided for by JIS A 5758 shall be used.
- (9) In case glass wool or rock wool is used for thermal insulation, glass wool shall be used for specimens.
- (10) Specimens shall be kept in the air-dry condition. The definition of “air-dry condition” used herein is the condition of a wooden component material having a water content of 15% or under, of a material that contains crystalline water, such as gypsum, having a water content of 2% or under when it is dried at 40°C until its weight becomes constant, and of other materials having a water content of 5% or under. However, this condition shall not be applied to cases where such as equilibrium is confirmed to be established in a room that the water content therein is kept almost constant.

### 3. Test Equipment

- (1) The furnace shall be capable to reproduce the standard temperature curve that specified in 4. almost uniform over the entire test surface.

- (2) The furnace shall be capable of heating one side of a specimen.
- (3) A minimum of 9 hot junctions of thermocouples used to measure the heating temperature (herein “in-furnace thermocouples”) shall be uniformly distributed over the test surface and placed 100 mm away from the test surface.
- (4) The test equipment shall have a weight or a force application device that can reproduce the weight specified in (2) of 4.
- (5) The heating furnace shall be equipped with a device to measure in-furnace pressure.

#### 4. Test Conditions

- (1) A specimen shall be so heated that the temperature measured by an in-furnace thermocouple (herein “heating temperature”) will take the value, within the allowable range, as calculated by the following equation:

$$T = 345 \log_{10} (8t + 1) + 20$$

where T is average heating temperature (°C) and t is the lapse of time (min.) since the beginning of the test.

The allowable error for the heating temperature, de, shall take the following value except for specimens that contain a large volume of flammable material and for which a sudden firing of the flammable material is explicitly confirmed to have increased the average in-furnace temperature.

- a)  $5 < t \leq 10$       $de \leq 15$  (%)
- b)  $10 < t \leq 30$       $de = \{15 - 0.5 (t - 10)\}$  (%)

$$de = 100 (A - As) / As$$

where A is the area under the actual average heating temperature’s time curve; As is the area under the standard temperature time curve; and t is the lapse of time (min.) since the beginning of the test.

The area shall be calculated by accumulating the values at an interval shorter than 1 min. for a) and shorter than 5 min. for b).

- (2) In the case of construction that supports a stationary vertical load, the test shall be conducted while a load is applied so that it will cause a degree of stress equivalent to the

long-term allowable unit stress for sustained loads on the section of the principal parts necessary for structural strength of the specimen.

- (3) Measurement specified by 5. shall be made while heating the specimen for 20 minutes.
- (4) The pressure shall be applied on the surface of test specimen as laid down in a) to c) below:
  - a) Pressure gradient in the vertical direction in the heating furnace shall be 8 Pa for a height of 1,000 mm on the average.
  - b) The error of pressure applied on the test surface shall be adjusted so that it will be  $\pm 5$  Pa from the beginning of the test to the elapse of 5 minutes and  $\pm 3$  Pa from the beginning of the test to the elapse of 10 minutes.
  - c) Pressure on the test surface of a vertical member shall have a gradient of 0 at a height of 500 mm from the bottom of the specimen. Provided that the neutral axial height shall be adjusted so as not to exceed 20 Pa at the upper end of the specimen.

## 5. Measurement

- (1) Temperature and contraction shall be measured once every less than a minute.
- (2) In case the specimen of a construction that supports a stationary vertical load is tested with loads on, the value of contraction in the axial direction and the rate of contraction in the axial direction shall be measured.
- (3) Temperature on the rear surface shall be measured in compliance with the following rules of a) to c):
  - a) Rear surface temperature shall be measured by fixed thermocouples and movable thermocouples.
  - b) Hot junctions of the fixed thermocouples shall be uniformly installed in a minimum of five on the surface opposite to the heated surface.
  - c) Rear surface temperature shall be measured by fixed thermocouples once every less than a minute. Movable thermocouples shall be immediately applied to any location whose temperature is supposed to be high .

- (4) Non-heated surfaces shall be visually observed to check for the generation of flames or the presence of cracks through which flames could permeate. The term “crack through which flames could permeate” used in this document is a crack through which flames move up onto the non-heated surface or through which the inside of the heating furnace is seen.

## 6. Judgment

If a specimen satisfies the following criteria as the result of the test, the material shall be judged acceptable.

- (1) In the case of an external wall that supports a stationary vertical load, the Maximum value of contraction in the axial direction and the Maximum rate of contraction in the axial direction shall be equal to or smaller than the following during the period from the beginning of the test to the elapse of 20 minutes:

Maximum value of contraction in the axial direction (mm):  $h/100$

Maximum rate of contraction in the axial direction (mm/min.):  $3 h/1,000$

where h is the initial height of the specimen (mm).

- (2) The rear surface temperature of a specimen shall be 140 K or under in the average or 180 K or under at maximum during the period from the beginning of the test to the elapse of 20 minutes.
- (3) An external wall specimen shall satisfy the following criteria during the period from the beginning of the test to the elapse of 20 minutes:
- a) There shall be no spurting of flames that continuously spread to the non-heated side for over 10 seconds.
  - b) There shall be no flames that continuously exist at the non-heated surface for over 10 seconds.
  - c) There shall be no cracking or other damage that could be used for a passage of flames.

#### 4.5 Roof flame insulating performance test and evaluation procedure

Performance evaluation required by Clause 3-1, Article 109, Order (Roof of Buildings with Fireproof Performance Equal to That of Quasi-Fireproof Buildings) and Clause 1-3, Article 113, Order (Roof of Building Portions Having Fire Preventive Walls) shall be conducted by the following test and evaluation procedure:

##### 1. General

- (1) Roof flame insulating performance test shall be conducted on a set of specimen specified in 2. and measured as specified in 5. by using the test equipment specified in 3. in the test condition specified in 4. If the measurement result satisfies the judgment criteria specified in 6. the specimen shall be classified.

##### 2. Specimen

- (1) The composition and material the actual product system. Providing that the actual component has two or more variations with different specifications, either a) or b) in the following shall apply:
  - a) In case there are two or more types of sectional lack caused by grooving or other surface treatment given onto the surface of the fire preventive cladding, the type that has the largest total volume of lack shall be used as a specimen.
  - b) In case there are two or more types of composition or configuration for the surface of the fire preventive cladding, the type that has the greatest mass of organic compound shall be used as a specimen.
- (2) Dimensions, composition, and density of a specimen shall be within the allowable range.
- (3) The number of test specimens shall be two.
- (4) The form and size of a specimen shall be representing the actual product system except in cases where testing with a specimen sized identical to the actual one is extremely difficult. In such cases, the form and size of a specimen may be changed providing that the fire preventive performance of the specimen shall be kept the same by setting the longer side of the heated area to a minimum of 4,000 mm and the shorter side to a minimum of 3,000 mm (or a minimum of 2,000 mm in case the shorter side alone supports the specimen) or by maintaining the original material and composition, the

original fire preventive cladding application intervals, or the original spacing of roof trusses.

- (5) For the fixing interval of fire preventive cladding for a specimen, the largest interval among those actually used shall be chosen.
- (6) In cases where weak points, such as joints, from the viewpoint of fire preventive performance may appear when building construction is actually executed using these parts, the weak points shall be placed in the middle of the specimen. Application of fire preventive cladding shall be so arranged as to include as many weak points, such as joints, as possible within the effective heated area.
- (7) In case no sealant is specified for use in joints of fire preventive cladding, acrylic sealant or polyurethane sealant as provided for by JIS A 5758 shall be used.
- (8) In case glass wool or rock wool is used for thermal insulation, glass wool shall be used for specimens.
- (9) When there are two or more kinds of roofing materials to be applied on roofing boards, the heaviest one shall be used for specimens.
- (10) When there are two or more types of corrugated roofing sheets in terms of sectional dimension, the one with the lowest crown and the greatest crown-to-crown distance shall be used as a specimen.
- (11) For materials used as roof waterproofing, the one containing the greatest volume of organic compounds shall be chosen for a specimen.
- (12) Specimens shall be kept in the air-dry condition. The definition of “air-dry condition” used herein is the condition of a wooden component material having a water content of 15% or under, of a material that contains crystalline water, such as gypsum, having a water content of 2% or under when it is dried at 40°C until its weight becomes constant, and of other materials having a water content of 5% or under. However, this condition shall not be applied to cases where such an equilibrium is confirmed to be established in a room that the water content therein is kept almost constant.

### 3. Test Equipment

- (1) The furnace shall be capable to standard temperature curve that is specified in 4. almost uniform over the entire test surface.

- (2) The furnace shall be capable of heating the bottom side of a specimen.
- (3) A minimum of 6 hot junctions of thermocouples used to measure the heating temperatures (herein “in-furnace thermocouples”) shall be uniformly distributed over the test surface and placed 100 mm away from the specimen.
- (4) The test equipment shall have a weight or a force application device that can reproduce the weight as specified by (2) of 4.
- (5) The heating furnace shall be equipped with a device to measure in-furnace pressure.

#### 4. Test Conditions

- (1) A specimen shall be so heated that the temperature measured by an in-furnace thermocouple (herein “heating temperature”) will take the value, within the allowable range, as calculated by the following formula:

$$T = 345 \log_{10} (8t + 1) + 20,$$

where T is average heating temperature (°C) and t is the lapse of time (min.) since the beginning of the test.

The allowable error for the heating temperature, de, shall take the following value except for specimens that contain a large volume of flammable material and for which a sudden firing of the flammable material is explicitly confirmed to have increased the average in-furnace temperature.

- a)  $5 < t \leq 10$       $de \leq 15$  (%)
- b)  $10 < t \leq 30$       $de = \{15 - 0.5 (t - 10)\}$  (%)

$$de = 100 (A - A_s) / A_s$$

where A is the area under the actual average heating temperature’s time curve; A<sub>s</sub> is the area under the standard temperature time curve; and t is the lapse of time (min.) since the beginning of the test.

The area shall be calculated by accumulating the values at an interval shorter than 1 min. for a) and shorter than 5 min. for b).

- (2) A roof specimen shall be demarcated into sections of 1 m<sup>2</sup> or less, and a concentrated load of 65 kg shall be applied to the center of each of these sections during the test.

- (3) In case the fulcrum-to-fulcrum distance for an actual roof exceeds the testable maximum fulcrum-to-fulcrum distance, a load that is generally supported by the actual fulcrum-to-fulcrum distance shall be applied to the specimen.
- (4) In the case of roofs built by the continuous girder method, that actual type of construction and loading conditions shall be reproduced before testing.
- (5) Measurement as specified by 5. shall be made while heating the specimen for 20 minutes.
- (6) The positive pressure difference of 20 Pa at a height of 100 mm from the bottom shall be applied on the test specimen. The error of pressure applied on the test surface shall be adjusted so that it will be  $\pm 5$  Pa from the beginning of the test to the elapse of 5 minutes and  $\pm 3$  Pa from the beginning of the test to the elapse of 10 minutes.

## 5. Measurement

- (1) Temperature shall be measured once every less than a minute.
- (2) Non-heated surfaces shall be visually observed to check for the generation of flames or the presence of cracks through which flames could permeate. The term “crack through which flames could permeate” used in this document is a crack through which flames move up onto the non-heated surface or through which the inside of the heating furnace is seen.

## 6. Judgment

Each specimen after the heating test shall satisfy the following criteria during the period from the beginning of the test to the elapse of 20 minutes:

- a) There shall be no spurting of flames that continuously spread to the non-heated side for over 10 seconds.
- b) There shall be no flames that continuously exist at the non-heated surface for over 10 seconds.
- c) There shall be no cracking or other damage that could be used for a passage of flames.

#### 4.6 Floor Fire Preventive Performance Test and Evaluation procedure

Performance evaluation required by Clause 3-2-3, Article 109, Order (Floors and Ceilings Immediately there under of Buildings with Fireproof Performance Equal to That of Quasi-Fireproof Buildings) and Clause 2-1-4, Article 115, Order (Floors of Building Portions Requiring No Fire Preventive Walls) shall be conducted by the following test and evaluation methods:

##### 1. General

- (1) Floor fire preventive performance test shall be conducted on a set of specimen specified in 2. and measured as specified in 5. by using the test equipment specified in 3. under the test condition specified in 4. If the measurement result satisfies the judgment criteria as provided for in 6. herein, the specimen shall be judged as classified

##### 2. Specimen

- (1) The composition and material shall be representing the actual product system. Providing that the actual component has two or more variations with different specifications, either a) or b) in the following shall apply:
  - a) In case there are two or more types of sectional lack caused by grooving or other surface treatment given onto the surface of the fire preventive cladding, the type that has the largest total volume of lack shall be used as a specimen.
  - b) In case there are two or more types of composition or configuration for the surface of the fire preventive cladding, the type that has the greatest mass of organic compound shall be used as a specimen.
- (2) Dimensions, composition, and density of a specimen shall be within the allowable range.
- (3) The number of the specimen shall be two for each heated surface as specified in (2) of 3.
- (4) The form and size of a specimen shall be representing the actual product system except in cases where testing with a specimen sized identical to the actual component is extremely difficult. In such cases, the shape and size of a specimen may be changed providing that the shape of a specimen and the area to be heated may be either a) or b) as specified in the following or that the fire preventive performance of the specimen

shall be kept the same by maintaining the original material and composition, the original fire preventive cladding application intervals, or the original spacing of joists:

- a) In case the surface to be tested is the underneath side of the floor (undersurface or ceiling surface, which herein called the “undersurface”), the specimen shall be a rectangular panel measuring a minimum of 4,000 mm in the longer side and a minimum of 3,000 mm in the shorter side (or a minimum of 2,000 mm in case the shorter side alone supports the specimen) and as thick as the actual component system.
  - b) In case the surface to be tested is the top surface of the floor, the specimen shall be a rectangular panel measuring a minimum of 2,000 mm in the longer side and a minimum of 1,800 mm in the shorter side and as thick as the actual component system.
- (5) For the fixing interval of fireproof cladding for a specimen, the largest interval among those actually used shall be chosen.
  - (6) In cases where weak points, such as joints, from the viewpoint of fire preventive performance may appear when building construction is actually executed using these parts, the weak points shall be placed in the middle of the specimen. Application of fire preventive cladding shall be so arranged as to include as many weak points, such as joints, as possible within the effective heated area.
  - (7) In case no sealant is specified for use in joints of fire preventive cladding, acrylic sealant or polyurethane sealant as provided for by JIS A 5758 shall be used.
  - (8) In case glass wool or rock wool is used for thermal insulation, glass wool shall be used for specimens.
  - (9) Specimens shall be kept in the air-dry condition. The definition of “air-dry condition” used herein is the condition of a wooden component material having a water content of 15% or under, of a material that contains crystalline water, such as gypsum, having a water content of 2% or under when it is dried at 40°C until its weight becomes constant, and of other materials having a water content of 5% or under. However, this condition shall not be applied to cases where such as equilibrium is confirmed to be established in a room that the water content therein is kept almost constant.

### 3. Test Equipment

- (1) The furnace shall be capable to reproduce the standard temperatures that change with time as specified in 4. almost uniform over the entire test surface.
- (2) The heating furnace shall be capable of heating the bottom side of a specimen.
- (3) A minimum of eight hot junctions of thermocouples used to measure the heating temperatures (herein “in-furnace thermocouples”) shall be uniformly distributed over the test surface and placed 100 mm away from the specimen.
- (4) The test equipment shall have a weight or a force application device that can reproduce the weight as specified by (2) of 4.
- (5) The heating furnace shall be equipped with a device to measure in-furnace pressure.

#### 4. Test Conditions

- (1) A specimen shall be so heated that the temperature measured by an in-furnace thermocouple (herein “heating temperature”) will take the value, within the allowable range, as calculated by the following equation:

$$T = 345 \log_{10} (8t + 1) + 20,$$

where T is average heating temperature (°C) and t is the lapse of time (min.) since the beginning of the test.

The allowable error for the heating temperature, de, shall take the following value except for specimens that contain a large volume of flammable material and for which a sudden firing of the flammable material is explicitly confirmed to have increased the average in-furnace temperature.

- a)  $5 < t \leq 10$        $de \leq 15$  (%)
- b)  $10 < t \leq 30$        $de = \{15 - 0.5 (t - 10)\}$  (%)

$$de = 100 (A - As) / As$$

where A is the area under the actual average heating temperature’s time curve; As is the area under the standard temperature time curve; and t is the lapse of time (min.) since the beginning of the test.

The area shall be calculated by accumulating the values at an interval shorter than 1 min. for a) and shorter than 5 min. for b).

- (2) In the case of heating the undersurface of the specimen, the test shall be conducted while a load is applied so that it will cause a degree of stress equivalent to the long-term allowable unit stress for sustained loads on the section of the principal parts necessary for structural strength of the specimen. Providing that in case a room of the building in which the component is used has a specific use, a load as specified by Article 85 of the Order shall be applied to the specimen.
- (3) In case the fulcrum-to-fulcrum distance for an actual roof exceeds the testable maximum fulcrum-to-fulcrum distance, a load that is generally supported by the actual fulcrum-to-fulcrum distance shall be applied to the specimen.
- (4) In the case of floors built by the continuous girder method, that actual type of construction and loading conditions shall be reproduced before testing.
- (5) Measurement as specified by 5. shall be made while heating the specimen for 30 minutes.
- (6) The positive pressure difference of 20 Pa at a height of 100 mm from the bottom shall be applied on the surface of the specimen (except for cases where the top surface of the specimen is heated). The error of pressure applied on the test surface shall be adjusted so that it will be  $\pm 5$  Pa from the beginning of the test to the elapse of 5 minutes and  $\pm 3$  Pa from the beginning of the test to the elapse of 10 minutes.

## 5. Measurement

- (1) Temperature and deflection shall be measured once every less than a minute.
- (2) In the case of the test surface being the undersurface of a specimen, the value of deflection and the rate of deflection of the specimen shall be measured.
- (3) Temperature on the rear surface of a specimen shall be measured in compliance with the following rules of a) to c):
  - a) Rear surface temperature shall be measured by fixed thermocouples and movable thermocouples.
  - b) Hot junctions of the fixed thermocouples shall be uniformly installed in a minimum of five on the unheated surface.

- c) Rear surface temperature shall be measured by fixed thermocouples once every less than a minute. For movable thermocouples, in case there occurs any part judged to be heated to a very high temperature, that part shall be immediately measured.
- (4) Non-heated surfaces shall be visually observed to check for the generation of flames or the presence of cracks through which flames could permeate. The term “crack through which flames could permeate” used in this document is a crack through which flames move up onto the non-heated surface or through which the inside of the heating furnace is seen.

## 6. Judgment

If a specimen satisfies the following criteria as the result of the test, the material shall be judged acceptable.

- (1) In case the test surface is the undersurface of the floor, the maximum deflection and the rate of deflection shall take the following value or smaller during the period from the beginning of the test to the elapse of 30 minutes:

Maximum value of deflection (mm):  $L^2/400 d$

Maximum rate of deflection(mm/min.):  $L^2/9000 d$

where

L is the fulcrum-to-fulcrum distance of the specimen (mm) and d is the distance from the compressive edge of the specimen to the tensile edge of the specimen (mm).

- (2) The rear surface temperature of a specimen shall be 140 K or under in the average or 180 K or under at maximum during the period from the beginning of the test to the elapse of 30 minutes.
- (3) An external wall specimen shall satisfy the following criteria during the period from the beginning of the test to the elapse of 30 minutes:
- a) There shall be no spurting of flames that continuously spread to the non-heated side for over 10 seconds.
  - b) There shall be no flames that continuously exist at the non-heated surface for over 10 seconds.
  - c) There shall be no cracking or other damage that could be used for a passage of flames.

#### 4.7 Eaves flame insulating performance test and evaluation procedure

Performance evaluation required by Clause 2-2-1-4-3, Article 115, Order (Eaves, etc. of Special Buildings Requiring No Fireproof Building) shall be conducted by the following test and evaluation procedure:

##### 1. General

- (1) Eaves flame insulating performance test shall be conducted on a set of specimen specified by 2. and measured as specified in 5. by using the test equipment as specified in 3. under the test condition specified in 4. If the measurement result satisfies the judgment criteria as provided for in 6. herein, the specimen shall be judged as classified.
- (2) Eaves flame insulating performance test shall be given to any sides of the component which are confirmed to be simultaneously exposed to the heat of fire. This rule shall not be applied to side walls if any exposure side of the side wall is clearly certified to be as fireproof as or more fireproof than other sides by the fireproof performance test separately conducted by a certified performance evaluation institute. In this case, the eaves flame insulating performance test may be omitted for that side of the side wall.

##### 2. Specimen

- (1) The composition and the material of the specimen shall be representing the actual product system. Providing that the actual component has two or more variations with different specifications, either a) or b) in the following shall apply:
  - a) In case there are two or more types of sectional lack caused by grooving or other surface treatment given onto the surface of the fire preventive cladding, the type that has the largest total volume of lack shall be used for specimens.
  - b) In case there are two or more types of composition or configuration for the faced or dressed surface of the fire preventive cladding, the type that has the greatest mass of organic compound shall be used as a specimen.
- (2) Dimensions, composition, and density of a specimen shall be within the allowable range.

- (3) The number of the specimen shall be two for each heated surface as specified in (2) of 3. herein. Providing that the test may only be given to either one side of those side walls whose section is symmetrical.
- (4) The shape and size of a specimen shall be representing the actual component system except in cases where testing with a specimen sized identical to the actual one is extremely difficult. In such cases, the shape and size of a specimen may be changed providing that the shape of a specimen and the area to be heated may be either a) or b) as specified in the following or that the fire preventive performance of the specimen shall be kept the same by maintaining the original material and composition, the original fire preventive cladding application intervals, or the original spacing of studs or furring strips:
  - a) In the case of eaves, the specimen shall be a minimum of 1,800 mm in width and the projection and pitch of the eaves specimen shall be identical to the actual component system.
  - b) In the case of side walls, the specimen shall be a minimum of 3,000 mm in width and a minimum of 3,000 mm in height and as thick as the actual component system.
- (5) In case fire preventive cladding is applied in two or more ways, the lateral application method shall be used.
- (6) For the fixing interval of fire preventive cladding for specimens, the greatest interval among the intervals actually practiced shall be set.
- (7) In cases where weak points, such as joints, from the viewpoint of fire preventive performance may appear when building construction is actually executed using these parts, the weak points shall be placed in the middle of the specimen. Application of fire preventive cladding shall be so arranged as to include as many weak points, such as joints, as possible within the effective heated area.
- (8) In case no sealant is specified for use in joints of fire preventive cladding, acrylic sealant or polyurethane sealant as provided for by JIS A 5758 shall be used.
- (9) In case glass wool or rock wool is used for thermal insulation, glass wool shall be used for specimens.
- (10) When there are two or more kinds of roofing materials to be applied on roofing boards of the eaves, the heaviest kind shall be used for specimens.

- (11) When there are two or more types of sectional shape for corrugated roofing sheets to be applied on eaves, the one with the lowest crown and the greatest crown-to-crown distance shall be used for specimens.
- (12) For materials used as roof waterproofing, the one containing the greatest volume of organic compounds shall be chosen for a specimen.
- (13) Specimens shall be kept in the air-dry condition. The definition of “air-dry condition” used herein is the condition of a wooden component material having a water content of 15% or under, of a material that contains crystalline water, such as gypsum, having a water content of 2% or under when it is dried at 40°C until its weight becomes constant, and of other materials having a water content of 5% or under. However, this condition shall not be applied to cases where such as equilibrium is confirmed to be established in a room that the water content therein is kept almost constant.

### 3. Test Equipment

- (1) The furnace shall be capable to reproduce standard temperature curve that is specified in 4. almost uniform over the entire test surface.
- (2) The heating furnace shall be capable of heating the undersurface of an eaves specimen and either one side of a side wall specimen.
- (3) Hot junctions of thermocouples used to measure the heating temperatures (herein “in-furnace thermocouples”) shall be uniformly distributed over the test surface, and a minimum of 3 shall be installed on an eave and a minimum of 9 on a side wall. They shall be placed 100 mm away from the specimen.
- (4) The furnace shall be equipped with a device to measure in-furnace pressure.

### 4. Test Conditions

- (1) A specimen shall be so heated that the temperature measured by an in-furnace thermocouple (herein “heating temperature”) will take the value, within the allowable range, as calculated by the following equation:

$$T = 345 \log_{10} (8t + 1) + 20,$$

where T is average heating temperature (°C) and t is the lapse of time (min.) since the beginning of the test.

The allowable error for the heating temperature,  $d_e$ , shall take the following value except for specimens that contain a large volume of flammable material and for which a sudden firing of the flammable material is explicitly confirmed to have increased the average in-furnace temperature.

- a)  $5 < t \leq 10$       $d_e \leq 15$  (%)
- b)  $10 < t \leq 30$       $d_e = \{15 - 0.5(t - 10)\}$  (%)

$$d_e = 100 (A - A_s) / A_s$$

where  $A$  is the area under the actual average heating temperature's time curve;  $A_s$  is the area under the standard temperature time curve; and  $t$  is the lapse of time (min.) since the beginning of the test.

The area shall be calculated by accumulating the values at an interval shorter than 1 min. for a) and shorter than 5 min. for b).

- (2) Measurement as specified by 5. shall be made while heating the specimen for 20 minutes.
- (3) The pressure difference shall be applied on the surface of the test specimen as laid down in a) to d) below:
  - a) Pressure gradient in the vertical direction in the heating furnace shall be 8 Pa on the average for a height of 1,000 mm.
  - b) The error of pressure applied on the test surface shall be adjusted so that it will be  $\pm 5$  Pa from the beginning of the test to the elapse of 5 minutes and  $\pm 3$  Pa from the beginning of the test to the elapse of 10 minutes.
  - c) Pressure on the test surface of a vertical member shall have a gradient of 0 at a height of 500 mm from the bottom of the specimen. Provided that the neutral axial height shall be adjusted so as not to exceed 20 Pa at the upper end of the specimen.
  - d) Pressure on the test surface of a horizontal member shall be 20 Pa positive at a height of 100 mm from the bottom surface of the specimen.

## 5. Measurement

- (1) Temperature shall be measured once every less than a minute.

- (2) Non-heated surfaces shall be visually observed to check for the generation of flame or the presence of cracks through which flames could permeate. The term “crack through which flames could permeate” used in this document is a crack through which flames move up onto the non-heated surface or through which the inside of the heating furnace is seen.

## 6. Judgment

If a specimen satisfies the following criteria as the result of the test for a duration from the beginning of the test to the elapse of 20 minutes, the material shall be judged acceptable:

- a) There shall be no spurting of flames that continuously spread to the non-heated side for over 10 seconds.
- b) There shall be no flames that continuously exist at the non-heated surface for over 10 seconds.
- c) There shall be no cracking or other damage that could be used for a passage of flames.

#### 4.8 Fire preventive performance testing and evaluation method for columns

Performance evaluation required by Article 70 (Fire Preventive Coverings for Columns) of the Enforcement Order shall be conducted by the following test and evaluation procedure.

##### 1. General

- (1) Fire preventive performance testing of columns shall be conducted on a set of specimen as specified in 2, using testing equipment as specified in 3, under the conditions specified in 4. Measurement shall be carried out as specified in 5. If the measurements satisfy the criteria as specified in 6, the specimen shall be judged as classified.

##### 2. Specimens

- (1) The composition and the material of the specimen shall be representing the actual product system. However, if the actual product is covered by multiple specifications, the requirements stated in a) and b) below shall apply.
  - a) If there are multiple specifications concerning sectional lack caused by grooving or treatment to the surface of the fire preventive covering, the specimen shall be based on the specification in which the total lack by volume is greatest.
  - b) If there are multiple specifications concerning the composition and structure of a decorative surface layer applied to fire preventive covering, the specimen shall be based on the specification in which the total volume of organic compounds (hereinafter referred to as “organic substances”) is greatest.
- (2) The dimensions, composition and density of the materials in the specimen shall be within the allowable range.
- (3) The number of specimens shall be two , as provided for in 3(2).
- (4) The form and size of a specimen shall, in principle, be identical to the actual product system. However, if testing with a specimen identical to the actual one is extremely difficult, the form of the specimen and area to be heated may be specified as stated in a), or the form and size of the specimen may be modified, provided that there is no change in the material, composition, fireproof cladding application intervals or other characteristics of the specimen, resulting in an increase in the fireproof performance of the specimen.

- a) The cross-sectional shape and size shall be the same as the actual product system, and the length shall be at least 3,000 mm.
- (5) Specimens shall be in the air-dry condition. “Air-dry condition” is defined here as the condition in which the water content of components is 15% or lower in the case of wooden materials, and 2% or lower in the case of materials that contain crystalline water, such as gypsum, where such materials have been dried at 40°C until their weight becomes constant, and 5% or lower for other materials. However, this condition shall not be applied in cases where it has been confirmed that the water content in an indoor environment will be in an approximately balanced state.
- (6) Fireproof cladding on specimens shall be fixed at the largest interval used in the specifications for the actual product.
- (7) Where there will be points of vulnerability in terms of fire prevention, such as joints, when the product is used in buildings, such points of vulnerability shall be placed at the center of the specimen. Fireproof cladding, etc., shall be arranged so as to include as many weak points, such as joints, as possible within the effective heated area.
- (8) If no sealant is specified for use in joints in fireproof cladding, an acrylic or polyurethane sealant as stipulated in JIS A 5758 shall be used.

### 3. Test Equipment

- (1) The furnace shall be capable to reproduce the standard temperature curve that is specified in 4 uniform over the entire test surface.
- (2) The furnace shall be capable of heating all surfaces of the specimen that could be subjected to heating in the event of a fire.
- (3) At least 12 thermocouple hot junctions (hereinafter referred to as “in-furnace thermocouples”) shall be positioned uniformly over the test surface at a distance of 100 mm from the specimen to measure the temperature inside the furnace.
- (4) The test equipment shall include a force actuator capable of imposing a load as specified in 4(2).
- (5) The furnace shall be equipped with a device to measure the in-furnace pressure.

### 4. Test Conditions

- (1) The specimen shall be heated in such a way that the temperature as measured by the in-furnace thermocouples (hereinafter referred to as the “heating temperature”) over the passage of time is within an allowable margin of error from a value based on the following equation:

$$T = 345 \log_{10} (8t + 1) + 20$$

where T is the average heating temperature (°C) and t is elapsed time (min.)

The allowable margin of error for the heating temperature shall be a value determined from the following equation. However, this shall not apply if it is confirmed that the average temperature in the furnace has increased due to the sudden ignition of flammable materials in the case of specimens that contain large amounts of flammable materials.

a)  $5 < t \leq 10$      $de \leq 15$  (%)

b)  $10 < t \leq 30$              $de = \{15 - 0.5 (t - 10)\}$  (%)

$$de = 100 (A - A_s) / A_s$$

where A is the area of the actual average heating temperature/time curve, A<sub>s</sub> the area of the standard time/temperature curve, and t the elapsed test time (min.).

Areas shall be calculated by accumulating values at intervals not exceeding 1 minute for a) and 5 minutes for b).

- (2) In principle, specimens shall be tested under loads that exert stresses equivalent to sustained allowable unit stress on the cross-section of parts that are essential for structural strength.
- (3) The specimen shall be heated for 30 minutes while measurements are carried out as stipulated in 5.
- (4) The pressure difference shall be applied on the test surface as specified in a) and b).
- a) The average pressure gradient in the vertical direction in the heating furnace shall be 8 Pa per 1,000 mm of height.
- b) The margin of error for the pressure on the test surface shall be adjusted to  $\pm 5$  Pa for a period of 5 minutes from the start of the test, and  $\pm 3$  Pa for a period of 10 minutes from the start of the test.

## 5. Measurements

- (1) Temperature and contraction shall be measured at intervals not exceeding 1 minute.
- (2) The amount and speed of contraction along the axis of the specimen shall be measured.

## 6. Judgment

A material shall be judged to have met the requirements if specimens meet the following criteria based on the results of heating tests.

- (1) The requirements stipulated in a) must be satisfied by the end of the test (the time at which heating for a period equivalent to the required fireproofing period has been completed).
  - a) The maximum amount of contraction and maximum contraction speed along the axis of the specimen must not exceed the following values.

Maximum axial contraction (mm):  $h/100$

Maximum axial contraction speed (mm/min.):  $3h/1000$

where h is the initial height (mm) of the specimen.

#### 4.9 Flame insulating and quasi-flame insulating performance test and evaluation procedure

Performance evaluation required by Article 2 item (9-2)(b) of the Law (Fire Doors and Other Opening Protective Assemblies Specified by Cabinet Order), Article 64 of the Law (Opening Protective Assembly of Exterior Walls), Article 112 paragraph 1 of the Enforcement Order (Specified Opening Protective Assembly used for Fire Compartments), and Article 114 paragraph 5 of the Enforcement Order (Opening Protective Assembly for Use at Separation Walls, Partition Walls, and Dividing Walls of Quasi-fire-resistive Construction), shall be conducted by the following test and evaluation procedure:

##### 1. General

- (1) Flame insulating and quasi-flame insulating performance test of opening protective assembly (herein “performance tests of opening protective assembly”) shall be conducted on a specimen specified in 2, and measured as specified in 5 using the test equipment specified in 3, under the test conditions specified in 4. If the measurement result satisfies the judgment criteria as specified in 6, the specimen shall be judged as classified.
- (2) Performance tests of opening protective assembly shall be applied to fire doors and other opening protective assemblies.
- (3) Performance tests of opening protective assembly shall be performed on each side of the component which is confirmed to be simultaneously exposed to the heat of fire. This rule shall not be applied to cases where specifications of the assembly to be tested are proposed in two or more variations, the assembly designed after any one of such specifications had a separate performance test of opening protective assembly conducted by a designated/recognized performance evaluation body, and that specification has been confirmed by the test results to have a level of flame insulating performance equal to or higher than the specification to be tested hereunder. In this case, the test may be omitted for that specification. An exterior surface of specimens shall be tested for quasi-flame insulating performance required by Article 64 of the Law.

##### 2. Specimen

- (1) The composition and the material of the specimen shall, in general, be representing the actual product system. Parts that have already been confirmed as providing flame insulating performance, and parts that clearly do not contribute to the flame insulating

performance may be removed from the specimen. Providing that the actual component system has two or more variations with different specifications, either a) to d) in the following shall apply:

- a) In case there are two or more types of sectional lack caused by grooving or other surface treatment given onto the surface of the assembly, the type that has the largest total volume of lack shall be used for a specimen.
  - b) In case there are two or more types of composition or configuration system for the faced or dressed surface of the assembly, the type that has the greatest mass of organic compounds shall be used as a specimen.
  - c) In case the actual component system has accessories, such as a newspaper/post slot, door eye, grill, or vent opening, their specimens shall also have such accessories.
  - d) In case there is any specification in which the dimensions of a door or glass vary similarly, the specimen shall be of the maximum size.
- (2) There shall be one specimen for each surface to be heated. However, if there is only one side to be heated during a fire, there shall be two specimens for one surface heating.
  - (3) The form and size of a specimen shall be representing the actual component system except in cases where testing with a specimen of identical size as the actual component system would be extremely difficult because of the extremely large size of the part for which verification of flame insulating performance required. In such cases, the specimen may be a minimum of 3,000 mm in width and a minimum of 3,000 mm in height but shall be as thick as the actual component. However, in such cases it must have been shown that the performance of the specification to be assessed can be fully verified on the basis of the test results obtained.
  - (4) Specimens shall be kept in the air-dry condition. The definition of “air-dry condition” used herein is the condition of a wooden component material having a water content of 15% or under, or of a material that contains crystalline water, such as gypsum, having a water content of 2% or under when it is dried at 40°C until its weight becomes constant, and of other materials having a water content of 5% or under. However, this condition shall not be applied to cases where such as equilibrium is confirmed to be established in a room that the water content therein is kept almost constant.
  - (5) Each specimen shall be prepared as comprising a door, etc, a frame, and a surrounding wall as specified by (6). In case it is confirmed that there is any part which can be a weak point in terms of flame insulating performance in the actual component, its

specimen shall contain such part. As a general rule, weak points in terms of fire insulating performance may include the door case of a sliding door, newspaper/post slot opening, door eye, door closer, grill, lock, and vent sash.

- (6) The surrounding wall part more than 100 mm away from the specimen shall be constructed according to the standard construction specification. When the wet (mortar, etc.) and dry (fiber-mixed calcium silicate board, etc.) methods are available, the dry method shall be used for construction of such a wall. If the construction method of the wall cannot be identified, the following standard test surrounding wall shall be used:

Specification of the standard test surrounding wall (wooden post and beam method)

- 1) For specified opening protective assembly:  
double layer of calcium silicate boards impregnated with fibers (12 mm thick) or  
single layer of calcium silicate board impregnated with fibers (25 mm thick)
  - 2) For opening protective assembly:  
double layer of gypsum boards (12.5 mm thick)
- (7) If it is possible to judge among specifications in terms of fire safety advantage or disadvantage on the basis of existing test results or calculation results, the specimen with the greatest fire safety disadvantage can be used.

### 3. Test Equipment

- (1) The furnace shall be capable of applying standard temperature curve that change with time as specified in 4 herein almost evenly over the entire test surface.
- (2) The heating furnace shall be capable of heating one side of a specimen.
- (3) A minimum of 9 thermo-junctions of thermocouples used to measure the heating temperatures (herein “in-furnace thermocouples”) shall be uniformly distributed over the test surface and placed 100 mm away from the test surface. However, if the area of the test surface is extremely small, like a case of a fire damper, etc., the number of thermo-junctions of the in-furnace thermocouples can be reduced to one or two.
- (4) The heating furnace shall be equipped with a device to measure in-furnace pressure.

### 4. Test Conditions

- (1) Heating time duration shall be 20-minute, 45-minute, or 60-minute depending on the required heating time by Order.
- (2) A specimen shall be so heated that the temperature measured by an in-furnace thermocouple (herein “heating temperature”) will take the value, within the allowable range, as calculated by the following equation:

$$T = 345 \log_{10} (8t + 1) + 20$$

where T is average heating temperature (°C) and t is the lapse of time (min.) from the beginning of the test.

The allowable error for the heating temperature,  $de$ , shall take the following value except for specimens that contain a large volume of flammable material and for which a sudden firing of the flammable material is explicitly confirmed to have increased the average in-furnace temperature.

- a)  $5 < t \leq 10$       $de \leq 15$  (%)
- b)  $10 < t \leq 30$       $de = \{15 - 0.5 (t - 10)\}$  (%)
- c)  $30 < t \leq 60$       $de = \{5 - 0.083 (t - 30)\}$  (%)

$$de = 100 (A - A_s) / A_s$$

where A is the area under the actual average heating temperature’s time curve;  $A_s$  is the area under the standard temperature time curve; and t is the lapse of time (min.) from the beginning of the test.

The area shall be calculated by accumulating the values at an interval shorter than 1 min. for a) and shorter than 5 min. for b) and c).

- (3) Pressure shall be applied to the test surface as stated in a) to c) below:
  - a) The pressure gradient in the vertical direction in the heating furnace shall be 8 Pa on the average for a height of 1,000 mm.
  - b) The error of pressure applied on the test surface shall be adjusted so that it will be  $\pm 5$  Pa from the beginning of the test until 5 minutes have elapsed and  $\pm 3$  Pa from the beginning of the test until 10 minutes have elapsed.
  - c) The pressure on the test surface shall have a gradient of 0 at a height of 500 mm from the bottom of the specimen. The neutral axial height shall be adjusted so as

not to exceed 20 Pa at the upper end of the specimen. If the area of the test surface is small, like a case of a fire damper, etc., the pressure shall be adjusted to achieve a positive pressure not exceeding 20Pa across the entire test surface.

## 5. Measurement

- (1) The temperature shall be measured at intervals of less than a minute.
- (2) Non-heated surfaces shall be visually observed to check for the generation of flames or the presence of cracks through which flames could permeate. The term “crack through which flames could permeate” used in this document and in the following is a crack through which flames move up onto the non-heated surface or through which the inside of the heating furnace is seen.

## 6. Judgment

If a specimen satisfies the following criteria a) to c) as the results of the test, the material shall be judged acceptable:

- a) There shall be no spurting of flames that continuously spreads to the non-heated side for over 10 seconds.
- b) There shall be no flames that continuously exist on the non-heated surface for over 10 seconds.
- c) There shall be no cracking or other damage through which flames could permeate. Clearances at fire door thresholds and at the part of the shutter in contact with the floor (10 mm or under) shall be excluded.

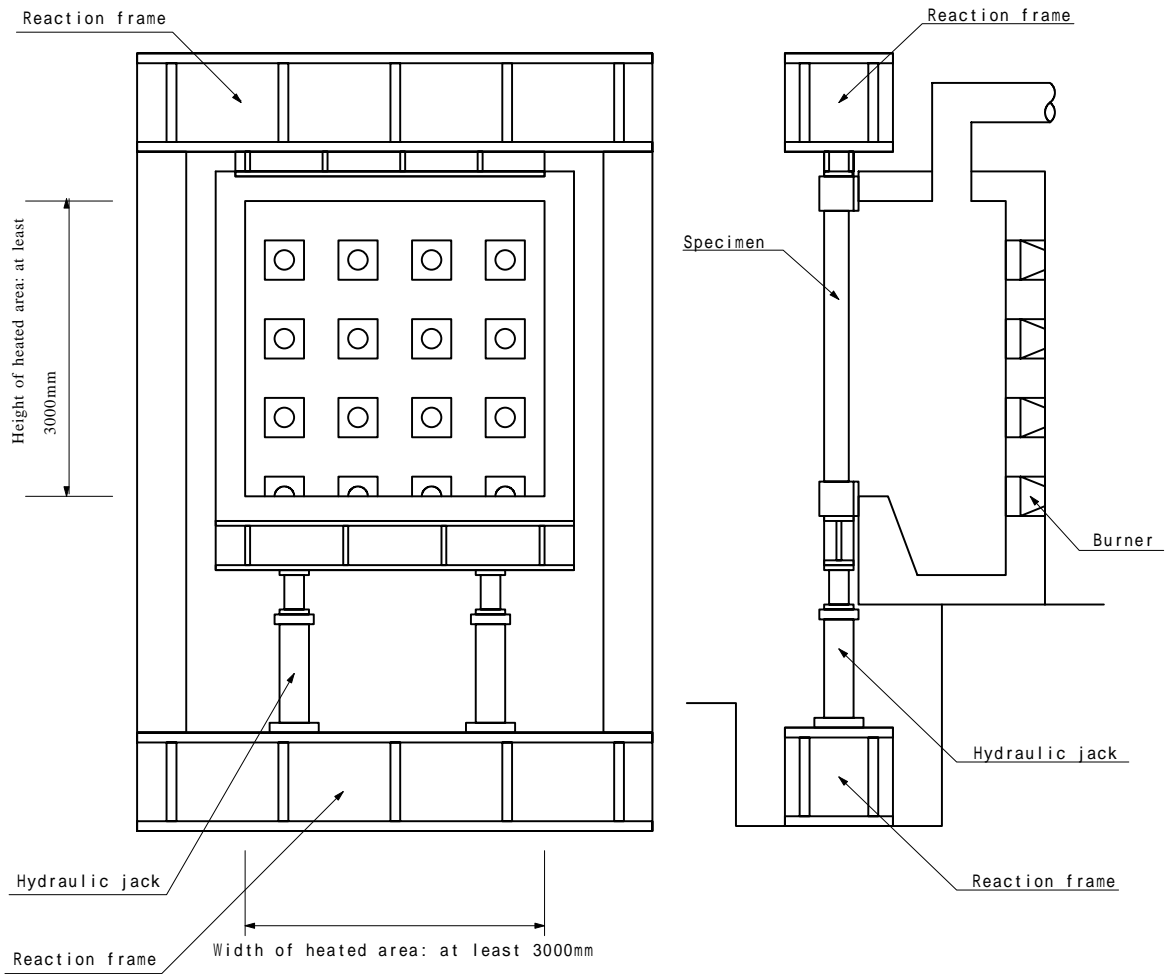

Wall Testing System (Dimensions in mm)

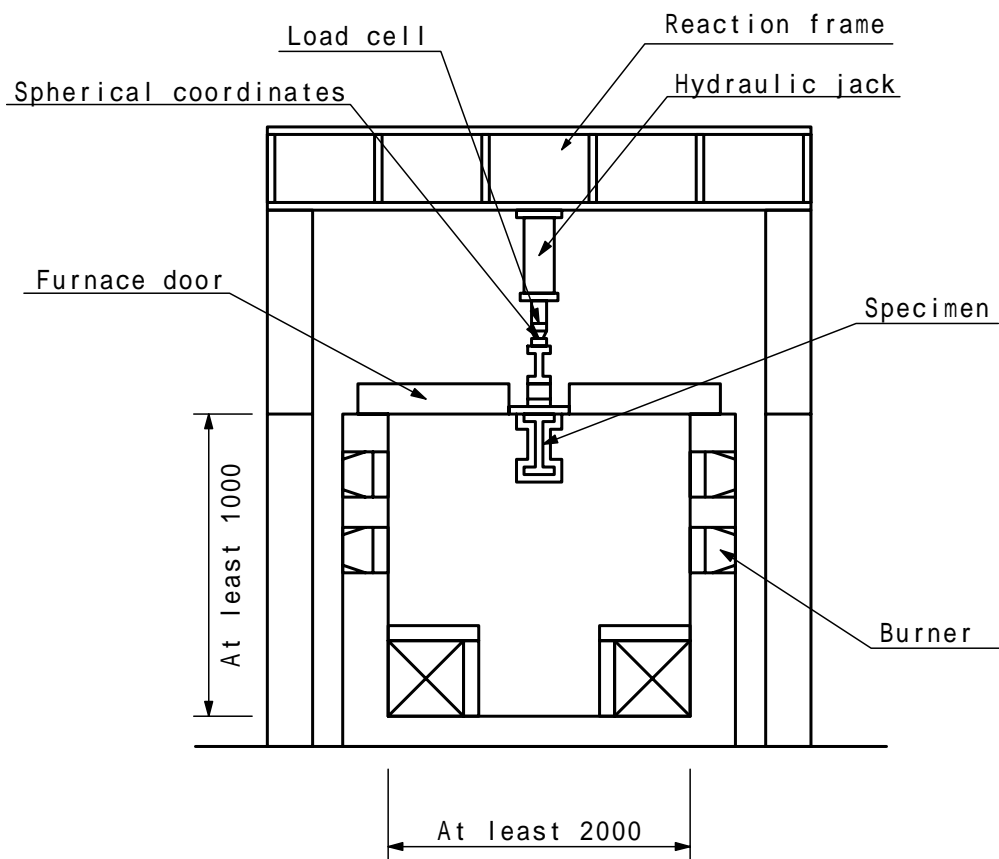
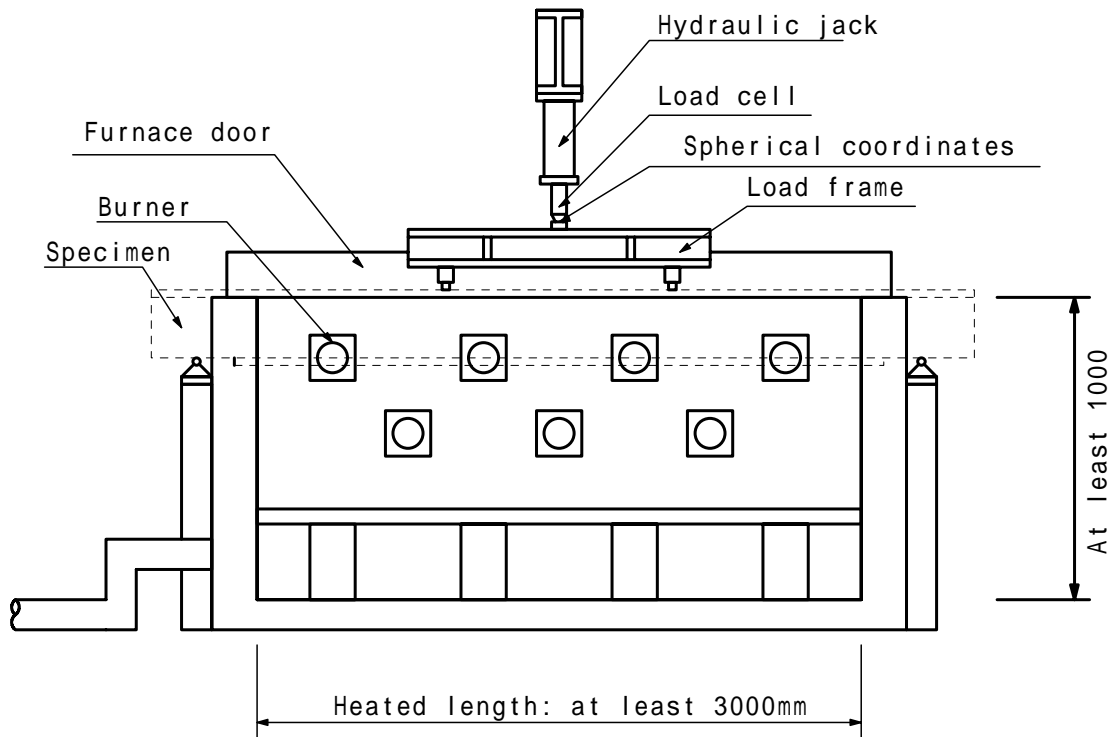

Testing System for Beams, Floors, Roofs and Stairs (Dimensions in mm)

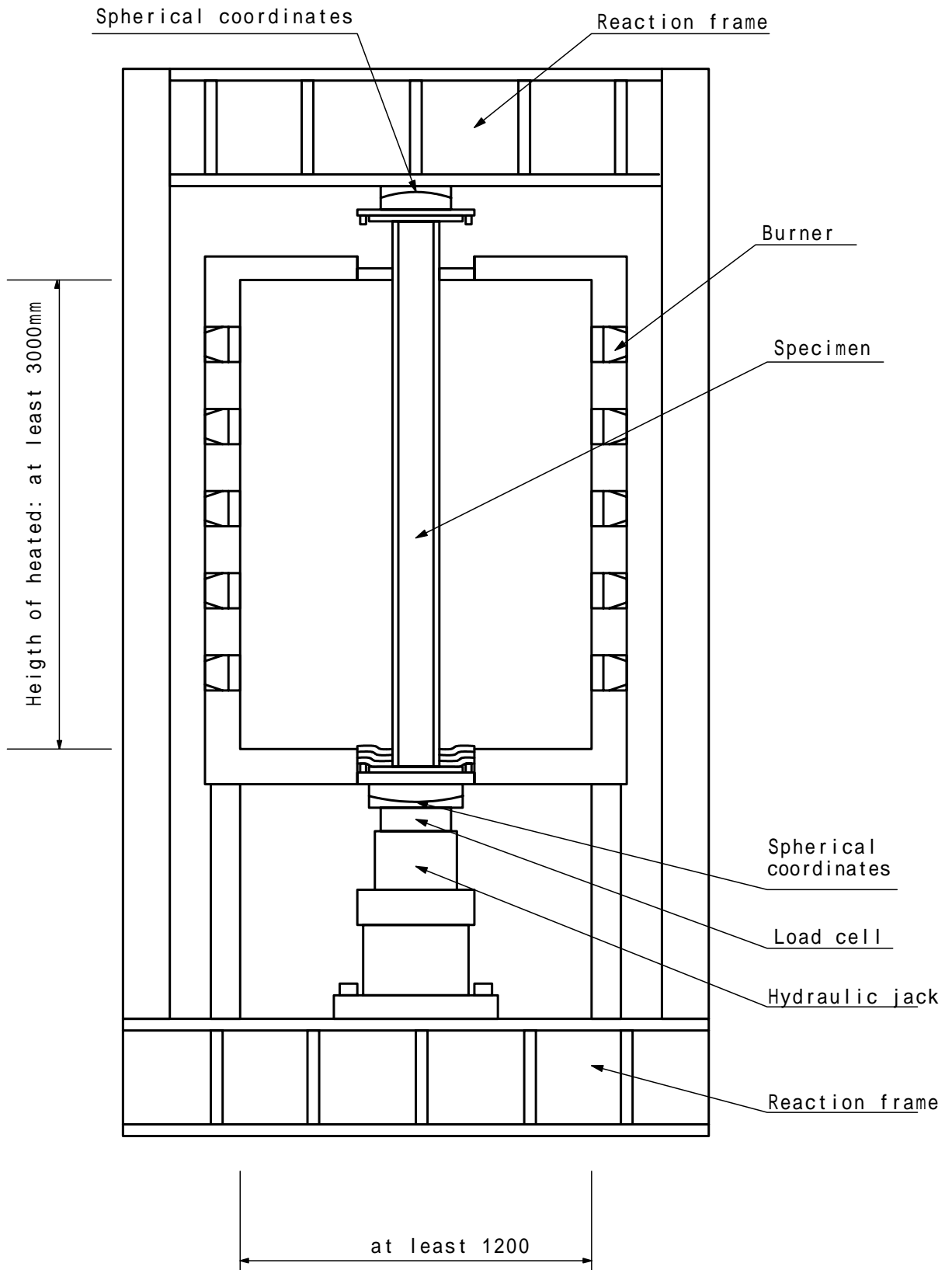

Testing System for columns (Dimensions in mm)

#### 4.10 Noncombustibility test and evaluation procedure

Performance evaluation for certification in compliance with Clause 9, Article 2 (Noncombustible Materials), shall be conducted by “4.10.1 Noncombustibility test and evaluation method” or “4.10.2 Heat Release test and evaluation procedure” for those included in the scope provided for by 4.10.0.

##### 4.10.0 Scope

- (1). This evaluation procedure shall be applied to noncombustible materials and quasi-noncombustible materials (hereinafter defined as those without any facing, dressing, or decoration on the surface) and fire-retardant materials (hereinafter defined as those without any facing, dressing, or decoration on the surface) with some facing, dressing, or decoration (defined as surface treatment, such as coating, applied on the surface for the purpose of improving design or appearance) applied on their base materials, in which the total mass of organic compounds in the decorative layer (including adhesive, if adhesive is used) is  $200 \text{ g/m}^2$  or less in the case of noncombustible materials, or  $100 \text{ g/m}^2$  or less in the case of quasi-noncombustible materials, combustible materials, and materials to which a wood-based material, etc., has already been applied to the base material (such as base paper on gypsum board), in which the total mass of organic compounds in the decorative layer, taking into account wood-based materials in the surface layer (including adhesive, if adhesive is used) is  $400 \text{ g/m}^2$  or less, using the testing and evaluation procedure for noncombustible materials as described in 4.10.1, or the heat release test and evaluation procedure described in 4.10.2.
- (2) For products other than those stipulated in (1), one of the following test and evaluation procedures shall be used.
  - i) The test and evaluation procedure for noncombustible products as described in 4.10.1, and the test and evaluation method for hazardous gas products described in 4.10.3
  - ii) The heat release test and evaluation procedure described in 4.10.2, and the test and evaluation procedure for hazardous gas products described in 4.10.3

##### 4.10.1 Noncombustibility test and evaluation procedure

###### 1. General

When a specimen is given a noncombustibility test and evaluation method, such a specimen shall be prepared as specified in 2. and measured as specified in 5. using the test equipment as

specified in 3. under the test condition as specified in 4. If the measurement result satisfies the criteria provided in 6. the specimen shall be judged as classified.

## 2. Specimen

- (1) A test specimen shall have the material and composition system representing that of the actual product.
- (2) Specimens shall be basically sampled from the actual product. If it is technically difficult to cut out a specimen from the actual product, a specimen shall be prepared to have the material composition, density, and other major conditions so contained or arranged as to be allowable for the evaluation of the performance of the actual product to be properly.
- (3) The number of specimens shall be three.
- (4) Each specimen shall be cylindrical in shape and  $44 \text{ mm} \pm 1 \text{ mm}$  in diameter and  $50 \text{ mm} \pm 3 \text{ mm}$  in height.
- (5) The thickness and height of each specimen shall be adjusted as written in a) to d):
  - a) In case the thickness of the product to be tested varies depending on part, the thinnest part shall be used for the test. Providing that in case such thinnest part is evaluated by the results of a noncombustibility test separately conducted by a designated or recognized evaluation institute to be appropriately noncombustible, the thickest part shall be used for the test.
  - b) In case the thickness of the thinnest part is 50 mm or under, the thinnest part shall be piled up one on top of the other except that the product of 50 mm in thickness shall be used as is for the test. For adjustment of the height of the specimen, piled-up specimens shall be properly shaved to adjust the height so as not to create any situation that benefits fire preventive performance of the product. This adjustment may include an arrangement that makes the total mass of the organic compound of one of the piled-up products become the maximum.
  - c) In case the thickness of the thinnest part is over 50 mm, piled-up specimens shall be properly shaved to adjust the height so as not to create any situation that benefits fire preventive performance of the product. This adjustment may include an arrangement that makes the total mass of organic compounds contained in the specimens become the maximum.

- d) In case the surface of the product is irregular due to surface treatment, the specimen shall be prepared so as to make the thinnest part become the central part of the specimen.
- (6) For those surface finish materials, such as wall paper or paint, designed to make the surface look good, which are used as surface facing materials for a number of setting bed materials (herein “base materials”) and produced as integral parts of such base materials, specimens of these products shall be prepared by the following rules from a) to c):
- a) Specimens shall be representing the actual product in terms of base material and manufacturing method.
  - b) Specimens shall be composed of base materials which are the thinnest.
  - c) In case the product has two or more base materials, the following base material shall be treated as the standard one and applied to preparation of specimens:
    - 1) In case two or more noncombustible materials, excluding metal panels, are used as base materials:

Gypsum board, 12.5 mm thick (noncombustible)
    - 2) In case two or more noncombustible materials, excluding metal panels (including steel panels) and gypsum board (noncombustible), are used as base materials:

Fiber-mixed calcium silicate board (noncombustible) with a nominal thickness of 10 mm or under and a specific gravity of 0.8
    - 3) In case metal panels, including steel panels, are used as base materials:

Galvanized steel panels with a (original plate) thickness of 0.27 mm
- (7) For those finish materials, such as wall paper or paint, which are applied to setting beds at a site, specimens of these products shall be prepared by the following rules a) to c):
- a) Specimens shall be identical to the actual product in terms of base material used onsite and manufacturing method practiced onsite.
  - b) Specimens shall be composed of base materials which are the thinnest.

c) In case there are two or more kinds of base materials used onsite, the following base material shall be treated as the standard one and applied to preparation of specimens:

1) In case two or more noncombustible materials, excluding metal panels, are used as base materials:

Gypsum board, 12.5 mm thick (noncombustible)

2) In case two or more noncombustible materials, excluding metal panels (including steel panels) and gypsum board (noncombustible), are used as base materials:

Fiber-mixed calcium silicate board (noncombustible) with a nominal thickness of 10 mm or under and a specific gravity of 0.8

3) In case metal panels, including steel panels, are used as base materials:

Galvanized steel panels with a (original plate) thickness of 0.27 mm

(8) Specimens shall be conditioned to have a constant mass at temperatures of  $23^{\circ}\text{C} \pm 2^{\circ}\text{C}$  and a relative humidity of  $50\% \pm 5\%$  before the test.

### 3. Test Equipment

(1) The heating furnace shall have a structure as shown in Attached Figure 1.

(2) The heating furnace shall be served by a heat source that is equipped with a voltage stabilizer.

(3) Hot junctions of thermocouples shall be installed 10 mm away from the inner wall of the heating furnace and at the center of the height of the furnace wall, as shown in Attached Fig. 1.

(4) The heating furnace shall be capable of maintaining the reading of the thermocouple (herein “in-furnace temperature”) at  $750^{\circ}\text{C} \pm 5^{\circ}\text{C}$  for a minimum of 30 minutes when heating without a specimen.

(5) The specimen holder shall have a structure as shown in Attached Fig. 2.

- (6) The specimen holder shall be made of heat-resistant steel wires, such as nickel-chromium or stainless steel, with similarly heat-resistant thin steel wire net attached to its bottom.
- (7) The specimen holder shall weigh  $15 \text{ g} \pm 2 \text{ g}$ .
- (8) The specimen holder shall be capable of being slung from the bottom of a tubular support bar made of heat-resistant material, such as nickel-chromium or stainless steel, measuring about 6 mm in outer diameter and about 4 mm in inner diameter.

#### 4. Test Conditions

- (1) The test shall be done as long as the final equilibrium temperature is reached after insertion of a specimen, which is at least 20 minutes.
- (2) In-furnace temperatures shall be measured by type K sheathed thermocouples with an outer diameter of 1.5 mm (1.6 mm) as specified by JIS C 1605 (Sheathed Thermocouple) and non-contact type hot junctions.
- (3) Heating of the test specimen shall be conducted after the heating furnace is adjusted to stabilize the in-furnace temperature at  $750^{\circ}\text{C} \pm 5^{\circ}\text{C}$  for a minimum of 20 minutes prior to inserting specimens.
- (4) Specimens shall be inserted into the central part of the core tube in such a manner that the center line of the side of the specimen is approximately in line with hot junctions of the thermocouples.

#### 5. Measurement

- (1) The mass of each specimen shall be measured to the unit of 0.1 g before specimens are inserted to the furnace.
- (2) In-furnace temperatures shall be measured for the duration from the time of specimen insertion to the final equilibrium temperature and the readings shall then be recorded.
- (3) After heating, specimens shall be cooled down in the desiccator to room temperature and the mass of each specimen shall then be measured. During and after the test, carbonated parts or shards of specimens that fell inside the core tube or elsewhere shall be recovered and their mass shall be added to the above mentioned mass as unburned parts of the specimens.

## 6. Judgment

If a specimen satisfies the following criteria as the result of the test, the product shall be judged acceptable:

- (1) In-furnace temperatures shall not exceed the final equilibrium temperature by over 20 K for 20 minutes from the beginning of heating.
- (2) Mass reduction rate of each specimen after the end of heating shall be 30% or under.

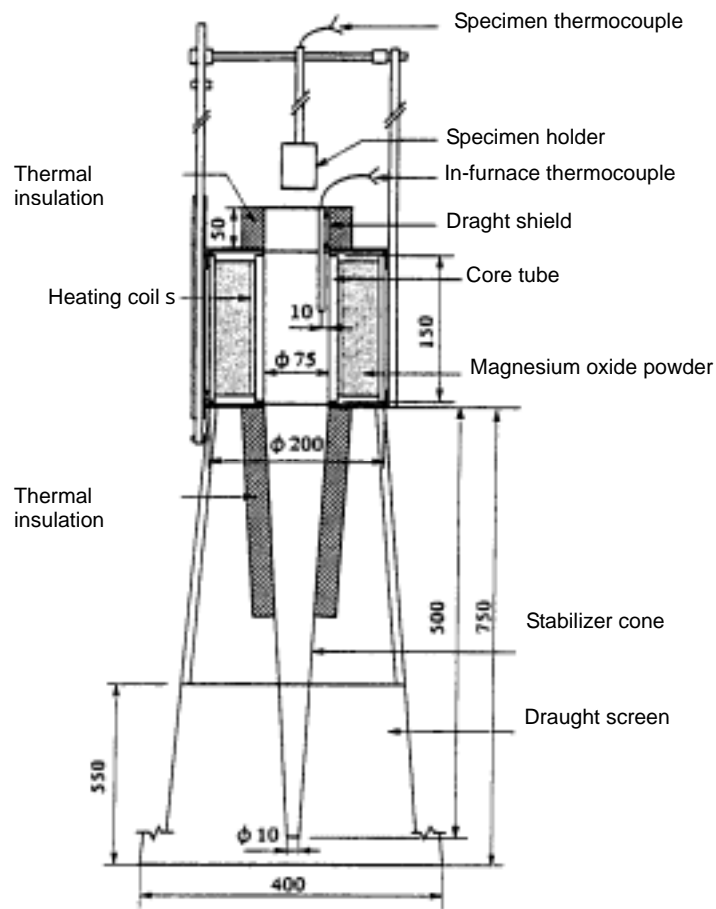

**Attached Fig. 1 Heating furnace (unit: mm)**

Outer diameter

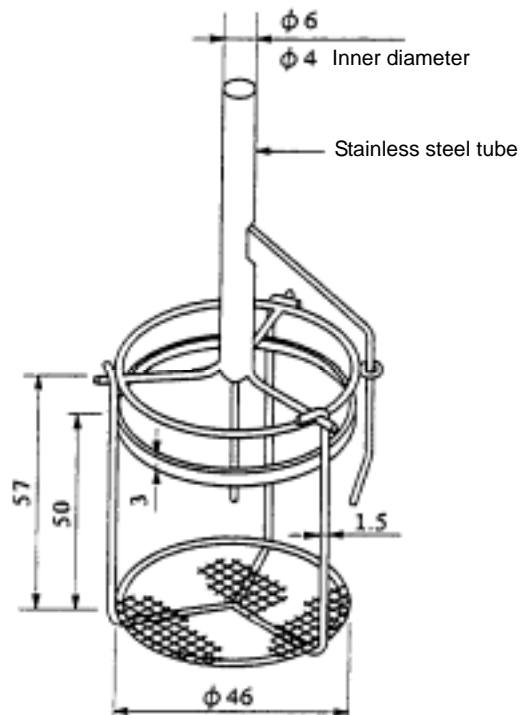

**Attached Fig. 2 Specimen holder (unit: mm)**

#### 4.10.2 Heat release test and evaluation method

##### 1. General

When a specimen is given for a heat release test, such a specimen shall be prepared as specified in 2. and measured as specified in 5. by using the test equipment as specified in 3. under the test condition as specified in 4. If the measurement result satisfies the judgment criteria as provided for in 6., the specimen shall be judged as classified.

##### 2. Specimen

- (1) Every specimen, which will be tested as specified, shall have the material and composition representing that of the actual product.
- (2) Specimens shall be basically sampled from the actual product provided that if it is technically difficult to cut out a specimen from the actual product, a specimen shall be prepared to have the material composition, density, and other major conditions so contained or arranged as to allow the performance of the actual product to be properly evaluated.
- (3) The number of specimens shall be three.

- (4) Each specimen shall be square with each side measuring  $99 \text{ mm} \pm 1 \text{ mm}$  and be 50 mm or under in height.
- (5) The thickness and height of each specimen shall be adjusted as shown by a) to d) as follows:
  - a) In case the thickness of the product to be tested varies depending on part, the thinnest part used be used for the test. In case the thinnest part is certified by the results of a noncombustibility test separately conducted by a certified evaluation institute to be appropriately noncombustible, the thickest part shall be used for the test.
  - b) In case the thickness of the thinnest part is 50 mm or under, the thinnest part shall be used for the test.
  - c) In case the thickness of the thinnest part is over 50 mm, the height shall be adjusted by shaving the rear side that is no likely to be exposed to flames while making sure that no situation that benefits the fire preventive performance of the product will be created. This adjustment may include an arrangement that makes the total mass of organic compounds contained in the specimen become the maximum.
  - d) In case the surface of the product is irregular due to surface treatment, the specimen shall be prepared so as to make the thinnest part become the central part of the specimen.
- (6) For those surface finish materials, such as wall paper or paint, designed to make the surface look good, which are used as surface facing materials for a number of setting bed materials (herein “base materials”) and produced as integral parts of such base materials, specimens of these products shall be prepared by the following rules from a) to c):
  - a) Specimens shall be identical to the actual product in terms of base material and manufacturing method.
  - b) Specimens shall be composed of base materials which are the thinnest.
  - c) In case the product has two or more base materials, the following base material shall be treated as the standard one and applied to preparation of specimens:
    - 1) In case two or more noncombustible materials, excluding metal panels, are used as base materials:

Gypsum board, 12.5 mm thick (noncombustible)

- 2) In case two or more noncombustible materials, excluding metal panels (including steel panels) and gypsum board (noncombustible), are used as base materials:

Fiber-reinforced calcium silicate board (noncombustible) with a nominal thickness of 10 mm or under and a specific gravity of 0.8

- 3) In case metal panels, including steel panels, are used as base materials:

Galvanized steel panels with a (original plate) thickness of 0.27 mm

- (7) For those finish materials, such as wall paper or paint, which are applied to setting beds at a site, specimens of these products shall be prepared by the following rules a) to c):

- a) Specimens shall be representing the actual product in terms of base material used onsite and manufacturing method practiced onsite.

- b) Specimens shall be composed of base materials which are the thinnest.

- c) In case there are two or more kinds of base materials used onsite, the following base material shall be treated as the standard one and applied to preparation of specimens:

- 1) In case two or more noncombustible materials, excluding metal panels, are used as base materials:

Gypsum board, 12.5 mm thick (noncombustible)

- 2) In case two or more noncombustible materials, excluding metal panels (including steel panels) and gypsum board (noncombustible), are used as base materials:

Fiber-reinforced calcium silicate board (noncombustible) with a nominal thickness of 10 mm or under and a specific gravity of 0.8

- 3) In case metal panels, including steel panels, are used as base materials:

Galvanized steel panels with a (original plate) thickness of 0.27 mm

- (8) Specimens shall be conditioned to have a constant mass at temperatures of  $23^{\circ}\text{C} \pm 2^{\circ}\text{C}$  and a relative humidity of  $50\% \pm 5\%$  before the test.

### 3. Test Equipment

- (1) The test equipment shall consist of a cone-shaped radiant electrical heater , ignition plug, radiation shield, specimen holder, gas analyzer, exhaust system designed to measure gas flow, and heat flux meter (Attached Fig. 1).
- (2) The radiant electric heater shall be capable of delivering a irradiance of  $50 \text{ kW/m}^2$  uniformly over the surfaces of the specimen.
- (3) The radiation shield shall be capable of protecting the specimen from irradiance before the beginning of the test.
- (4) The specimen holder shall have the shape of a square pan with an opening of  $106 \text{ mm} \pm 1 \text{ mm}$  at the top, and a depth of  $25 \text{ mm} \pm 1 \text{ mm}$ . The holder shall be constructed of stainless steel with a thickness of  $2.15 \text{ mm} \pm 0.25 \text{ mm}$ . On top of it there shall be a retainer frame. The frame shall be constructed with a thickness of  $1.9\text{mm}\pm 0.1\text{mm}$  in the shape of a box with an inside dimension of  $111 \text{ mm} \pm 1 \text{ mm}$  and a height of  $54\text{mm}\pm 1\text{mm}$ . The opening for the specimen face shall be  $94.0\text{mm}\pm 0.5\text{mm}$  square as shown in Attached Fig.2.
- (5) The exhaust system shall consist of a centrifugal exhaust fan rated for the operating temperature, a hood, intake and exhaust ducts, and an orifice plate flow meter. The distance between the bottom of the hood and the surface of the specimen shall be  $210 \text{ mm} \pm 50 \text{ mm}$ . The exhaust system shall be capable of developing flows up to  $0.024 \text{ m}^3/\text{s}$  at standard conditions of temperature and pressure. For measurement of the exhaust flow, a restrictive orifice with an internal diameter of  $57 \text{ mm} \pm 3 \text{ mm}$  shall be located between the hood and the duct. For sampling of exhaust gas, a ring sampler with 12 holes, whose diameter is  $2.2 \text{ mm} \pm 0.1 \text{ mm}$  in inner diameter, shall be installed at a position  $685 \text{ mm} \pm 15 \text{ mm}$  from the hood in such an orientation where the opening faces the direction reverse to the flow of exhaust. Temperature of exhaust gas shall be measured at a point  $100 \text{ mm} \pm 5 \text{ mm}$  at the upstream of the orifice at the center of the exhaust duct. The restrictive orifice shall be installed at a position where the measurement will not affected by the flow.
- (6) The gas analyzer shall be capable of continuously measuring concentrations of oxygen, carbon monoxide, and carbon dioxide in the exhaust gas.
- (7) The ignition plug shall be powered from a 10 kV transformer, induction coil system, etc. The ignition plug shall have a gap of  $3 \text{ mm} \pm 0.5 \text{ mm}$ . The electrode length and location of ignition plug shall be located  $13 \text{ mm} \pm 2 \text{ mm}$  on the central axis of the specimen unless otherwise specified.

- (8) The heat flux meter shall be of the SchmidtBoelter type with a design range of 100 kW/m<sup>2</sup> ± 10 kW/m<sup>2</sup>. The target receiving the heat shall be circular of 12.5 mm in a diameter, with surface emmissivity being 0.95 ± 0.05.

#### 4. Test Conditions

- (1) The test time shall be 20 minutes starting from the irradiation of radiation heat onto the specimen surface and the simultaneous generation of electric sparks provided that the measurement may be terminated when it is clearly indicated that no more continuation of burning is possible.
- (2) Each specimen shall be wrapped up both in the side and rear by a sheet of aluminum foil measuring 0.025 mm or more and 0.04 mm or less in thickness. Then, inorganic fibers (nominal thickness of 13 mm and a density of 65 kg/m<sup>3</sup>) shall be filled into the rear side and then the entire specimen shall be pressed into the specimen holder.
- (3) The irradiance of 50 kW/m<sup>2</sup> shall be applied to the surface of the specimen from the radiant electrical heater during the test.
- (4) Exhaust gas flow shall be adjusted to 0.024 m<sup>3</sup>/s ± 0.002 m<sup>3</sup>/s.
- (5) The surfaces of each specimen shall be covered by the radiation shield to prevent the specimen from radiated until the test begins.
- (6) The ignition plug shall be set at a predetermined position prior to moving the radiation shield.

#### 5. Measurement

- (1) Concentrations of oxygen, carbon monoxide, and carbon dioxide shall be measured at an interval of less than 5 seconds.
- (2) Heat release rate ( $\dot{q}$ ) shall be calculated by the following equation:

$$\dot{q} = \frac{1.10E(X^0_{O_2} - X_{O_2})}{(1.105 - 1.5X_{O_2})} \dot{V}_{298}$$

where

$$\dot{V}_{298} = C(\Delta p \cdot T_e)^{1/2} / 350 \quad (\text{flow in the duct at } 25^\circ\text{C})$$

$$E = 17.2 \times 10^3 \text{kJ/m}^3$$

$X_{O_2}^0$ : average value of oxygen concentration as identified by the one minute baseline measurement

$X_{O_2}$ : measured value of oxygen concentration during the test

Heat release rate per unit area ( $\dot{q}''$ ) shall be:

$$\dot{q}'' = \dot{q} / A_s$$

where

$A_s$ : initial exposure area of the specimen (0.0088 m<sup>2</sup>)

$C$  (orifice coefficient) shall be calculated from the oxygen concentration ( $X_{O_2}$ ) and differential pressure ( $\Delta p$ ) when a flow of methane whose heat release rate is equivalent to  $q_b = 5\text{kW} \pm 0.5\text{kW}$  as measured in accordance with the provision above in 5. under the predetermined exhaust flow.

$$C = q_b / (\Delta h_c / r_o \times 1.10) (T_e / \Delta p)^{1/2} (1.105 - 1.5 X_{O_2}) / (0.2095 - X_{O_2})$$

$q_b$ : heat release rate of methane supplied

$\Delta h_c / r_o$ :  $12.54 \times 10^3$  kJ/kg for methane

$T_e$ : gas temperature in exhaust duct (measured near the bi-directional probe)

## 6. Judgment

If a specimen satisfies the following criteria as the result of the test, the product shall be judged acceptable:

- (1) The total heat released in the duration of 20 minutes from the start of heating shall be 8 MJ/m<sup>2</sup> or under.
- (2) Any cracking or holes that penetrate to the rear side which are harmful in terms of fire preventive performance in the duration of 20 minutes from the start of heating shall not be observed.
- (3) The maximum heat release rate shall not exceed 200 kW/m<sup>2</sup> for over 10 seconds in the duration of 20 minutes from the start of heating.

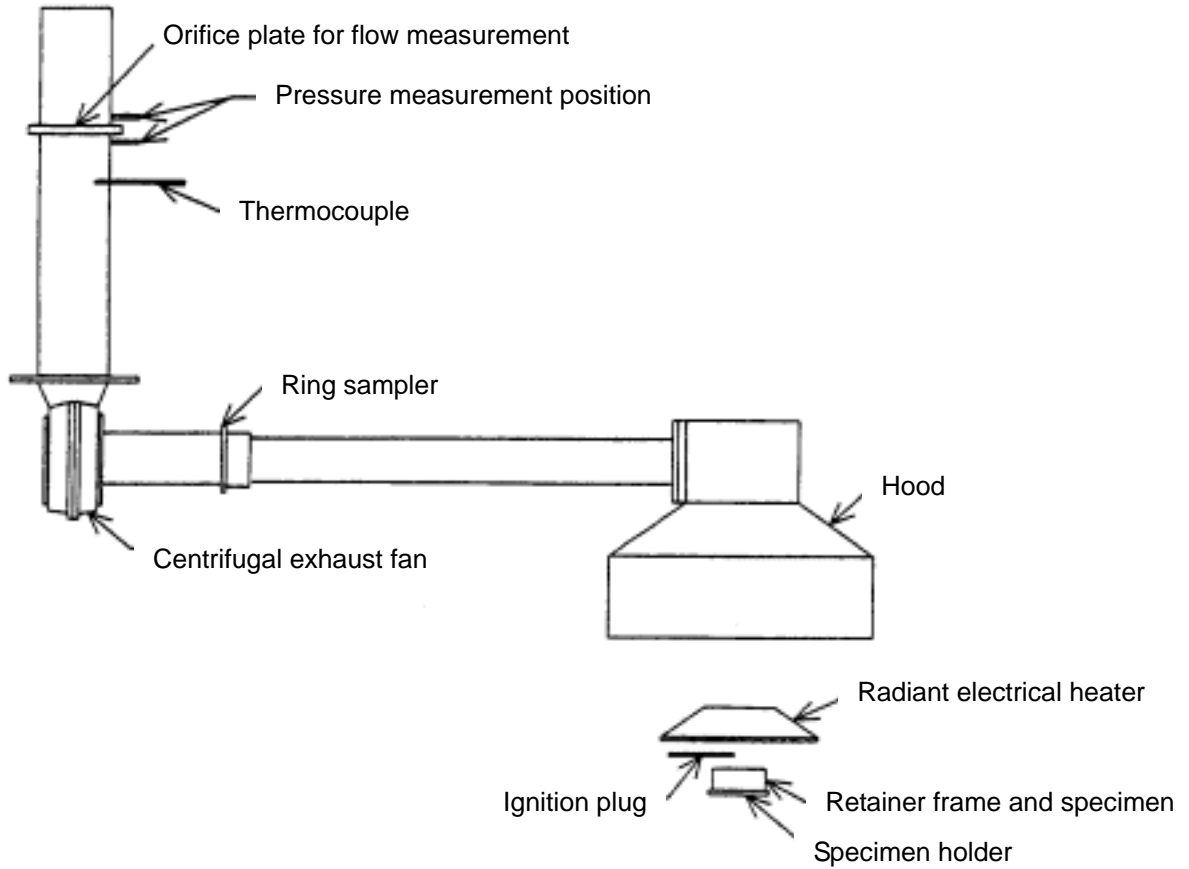

**Attached Fig. 1 Schematic diagram of test equipment (unit: mm)**

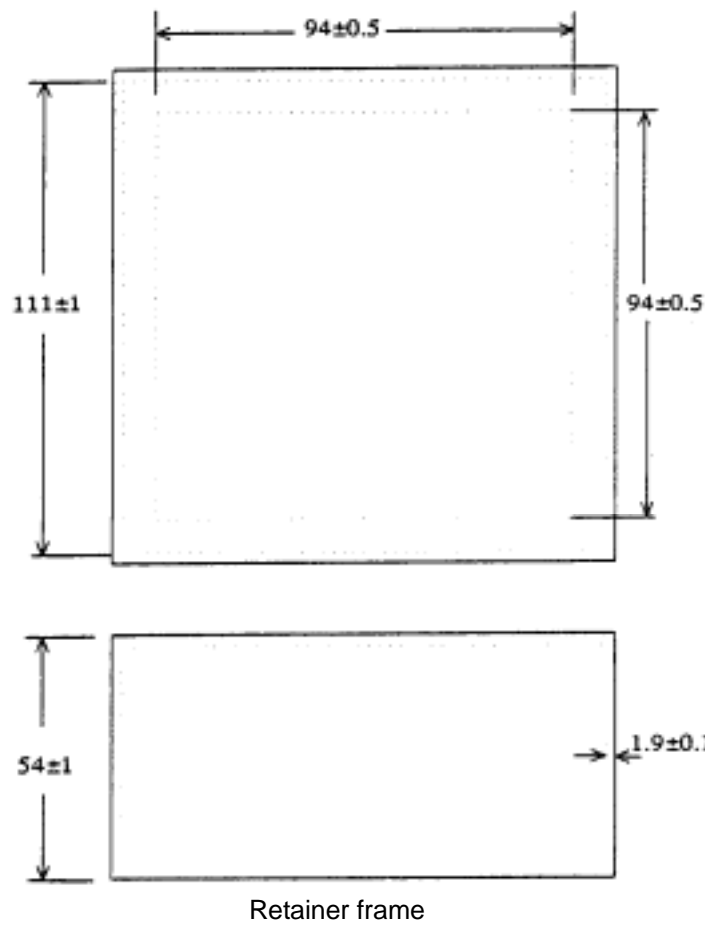
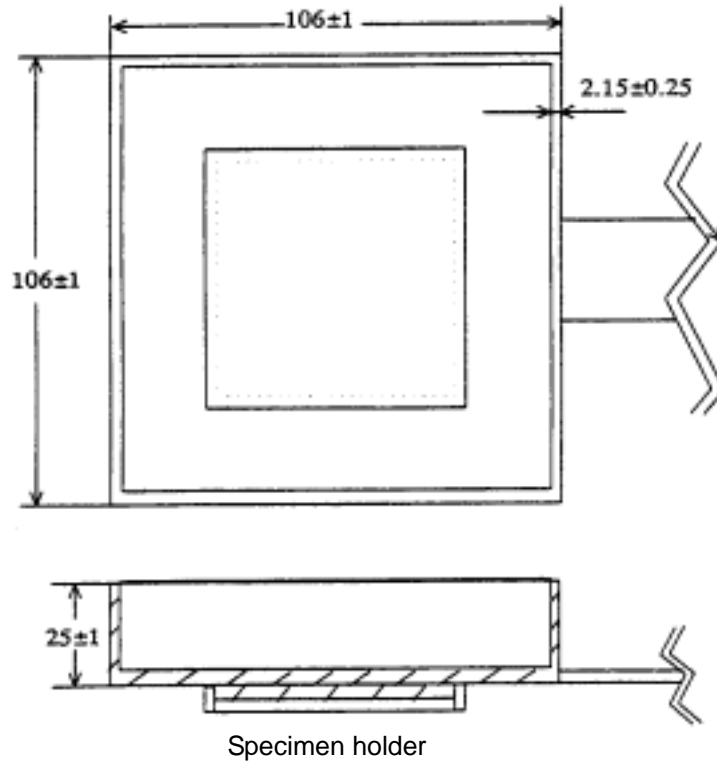

Attached Fig. 2 Specimen holder and retainer frame (unit: mm)

#### 4.11 Quasi-noncombustible performance test and evaluation method

Performance evaluation required by Clause 5, Article 1, Order (Quasi-noncombustible materials) shall be conducted by the following test and evaluation procedure.

##### 4.11.0 Scope

This evaluation shall be applied to noncombustible materials and quasi-noncombustible materials (hereinafter defined as those without any facing, dressing, or decoration on the surface) and fire retardant materials (hereinafter defined as those without any facing, dressing, or decoration on the surface) with some facing, dressing, or decoration (defined as surface treatment, such as coating, applied on the surface for the purpose of improving design or appearance) applied on their base materials, whose total mass of organic compounds of the surface-treated layer (including adhesive, if adhesive is used) is 200 g/m<sup>2</sup> or under for base materials of noncombustible materials and 100 g/m<sup>2</sup> or under for base materials of quasi-noncombustible materials, or in case some wooden material (such as base paper for board of gypsum board) is already applied onto the surface of that base material, whose the total mass of all organic compounds (including adhesive, if adhesive is used) including the wooden material part is 400 g/m<sup>2</sup> or under.

##### 4.10.1 Heat release test and evaluation method

#### 1. General

When a specimen is given for a heat release test and evaluation method, such a specimen shall be prepared as specified in 2. and measured as specified in 5. by using the test equipment as specified in 3. under the test condition as specified in 4. herein. If the measurement result satisfies the judgment criteria as provided for in 6., the specimen shall be judged as classified.

#### 2. Specimen

- (1) A specimen, which will be tested as specified, shall have the material and composition representing that of the actual product.
- (2) Specimens shall be basically sampled from the actual product provided that if it is technically difficult to cut out a specimen from the actual product, a specimen shall be prepared to have the material composition, density, and other major conditions so contained or arranged as to allow the performance of the actual product to be properly evaluated.
- (3) The number of specimens shall be three.

- (4) Each specimen shall be a square with each side measuring  $99 \text{ mm} \pm 1 \text{ mm}$  in length and be not higher than 50 mm.
- (5) The thickness and height of each specimen shall be adjusted as shown by a) to d) as follows:
- a) In case the thickness of the product to be tested varies depending on part, the thinnest part shall be used for the test. Providing that in case such thinnest part is certified by the results of a noncombustibility test separately conducted by a certified evaluation institute to be appropriately noncombustible, the thickest part shall be used for the test.
  - b) In case the thickness of the thinnest part of any product to be tested is 50 mm or under, that product having the thinnest part shall be used for the test.
  - c) In case the thickness of the thinnest part is over 50 mm, the rear side of the specimens, which is generally very unlikely to be exposed to flames, shall be properly shaved to adjust the height so as not to create any situation that benefits fire preventive performance of the product. This adjustment may include an arrangement that makes the total mass of organic compounds contained in the specimens become the maximum.
  - d) In case the surface of the product is irregular due to surface treatment, the specimen shall be prepared so as to make the thinnest part become the central part of the specimen.
- (6) For those surface finish materials, such as wall paper or paint, designed to make the surface look good, which are used as surface facing materials for a number of setting bed materials (herein “base materials”) and produced as integral parts of such base materials, specimens of these products shall be prepared by the following rules from a) to c):
- a) Specimens shall be identical to the actual product in terms of base material and manufacturing method.
  - b) Specimens shall be composed of base materials which are the thinnest.
  - c) In case the product has two or more base materials, the following base material shall be treated as the standard one and applied to preparation of specimens:
    - 1) In case two or more noncombustible materials, excluding metal panels, are used as base materials:

Gypsum board, 12.5 mm thick (noncombustible)

- 2) In case two or more noncombustible materials, excluding metal panels (including steel panels) and gypsum board (noncombustible), are used as base materials:

Fiber-reinforced calcium silicate board (noncombustible) with a nominal thickness of 10 mm or under and a specific gravity of 0.8

- 3) In case metal panels, including steel panels, are used as base materials:

Galvanized steel panels with a (original plate) thickness of 0.27 mm

- 4) In case two or more kinds of quasi-noncombustible materials are used as base materials:

Gypsum board, 9.5 mm thick (quasi-noncombustible)

- (7) For those finish materials, such as wall paper or paint, which are applied to setting beds at a site, specimens of these products shall be prepared by the following rules a) to c):

- a) Specimens shall be representing the actual product in terms of base material used onsite and manufacturing method practiced onsite.

- b) Specimens shall be composed of base materials which are the thinnest.

- c) In case there are two or more kinds of base materials used onsite, the following base material shall be treated as the standard one and applied to preparation of specimens:

- 1) In case two or more noncombustible materials, excluding metal panels, are used as base materials:

Gypsum board, 12.5 mm thick (noncombustible)

- 2) In case two or more noncombustible materials, excluding metal panels (including steel panels) and gypsum board (noncombustible), are used as base materials:

Fiber-reinforced calcium silicate board (noncombustible) with a nominal thickness of 10 mm or under and a specific gravity of 0.8

- 3) In case metal panels, including steel panels, are used as base materials:

Galvanized steel panels with a (original plate) thickness of 0.27 mm

- 4) In case two or more kinds of quasi-noncombustible materials are used as base materials:

Gypsum board, 9.5 mm thick (quasi-noncombustible)

- (8) Specimens shall be conditioned to have a constant mass at temperatures of  $23^{\circ}\text{C} \pm 2^{\circ}\text{C}$  and a relative humidity of  $50\% \pm 5\%$  before the test.

### 3. Test Equipment

- (1) The test equipment shall consist of a cone-shaped radiant electrical heater, ignition plug, radiation shield, specimen holder, gas analyzer, exhaust system designed to measure gas flow, and heat flux meter (Attached Fig. 1).
- (2) The radiant electric heater shall be capable of delivering a irradiance of  $50 \text{ kW/m}^2$  uniformly over the surfaces of the specimen.
- (3) The radiation shield shall be capable of protecting the specimen from irradiance before the beginning of the test.
- (4) The specimen holder shall have the shape of square pan with an opening of  $106 \text{ mm} \pm 1 \text{ mm}$  at the top, and a depth of  $25 \text{ mm} \pm 1 \text{ mm}$ . The holder shall be constructed of stainless steel with a thickness of  $2.15 \text{ mm} \pm 0.25 \text{ mm}$ . On top of it, there shall be a retainer frame. The frame shall be constructed with a thickness of  $1.9\text{mm}\pm 0.1\text{mm}$  in the shape of box with an inside dimension of  $111 \text{ mm} \pm 1 \text{ mm}$  and a height of  $54\text{mm}\pm 1\text{mm}$ . The opening for the specimen face shall be  $94.0\pm 0.5\text{mm}$  square as shig.2.
- (5) The exhaust system shall be consist of a centrifugal exhaust fan rated for the operating temperature, a hood, intake and exhaust ducts, and an orifice plate flow meter. The distance between the bottom of the hood and the surface of the specimen shall be  $210 \text{ mm} \pm 50 \text{ mm}$ . The exhaust system shall be capable of developing flows up to  $0.024 \text{ m}^3/\text{sat}$  the standard conditions of temperature and pressure. For measurement of the exhaust flow, a restrictive orifice with  $57 \text{ mm} \pm 3 \text{ mm}$  shall be located between the hood and the duct. For sampling of exhaust gas, a ring sampler with 12 holes, whose diameter is  $2.2 \text{ mm} \pm 0.1 \text{ mm}$  in inner diameter, shall be installed at a position  $685 \text{ mm} \pm 15 \text{ mm}$  from the hood in such an orientation that faces the opening to the direction reverse to the flow of exhaust. Temperature of exhaust gas shall be measured at a point  $100 \text{ mm} \pm 5 \text{ mm}$  upstream the orifice at the center of the exhaust duct. The

restrictive orifice shall be installed at a position where the measurement will not be affected by the flow.

- (6) The gas analyzer shall be capable of continuously measuring concentrations of oxygen, carbon monoxide, and carbon dioxide in the exhaust gas.
- (7) The ignition plug shall be powered from a 10 kV transformer, induction coil system, etc. The ignition plug shall have a gap of  $3 \text{ mm} \pm 0.5 \text{ mm}$ . The electrodes length and location of ignition plug shall be located  $13 \text{ mm} \pm 2 \text{ mm}$  on the central axis of the specimen unless otherwise specified.
- (8) The heat flux meter shall be a Schmidt Boelter type with a design range of  $100 \text{ kW/m}^2 \pm 10 \text{ kW/m}^2$ . The target receiving the heat shall be circular of 12.5 mm in a diameter, with surface emissivity being  $0.95 \pm 0.05$ .

#### 4. Test Conditions

- (1) The test time shall be 10 minutes starting from the irradiation of radiation heat onto the specimen surface and the simultaneous generation of electric sparks provided that the measurement may be terminated when it is clearly indicated that no more continuation of burning is possible.
- (2) Each specimen shall be wrapped up both in the side and rear by a sheet of aluminum foil measuring 0.025 mm or more and 0.04 mm or less in thickness. Then, inorganic fibers (nominal thickness of 13 mm and a density of  $65 \text{ kg/m}^3$ ) shall be filled into the rear side and then the entire specimen shall be pressed into the specimen holder.
- (3) The irradiance of  $50 \text{ kW/m}^2$  shall be applied to the surface of the specimen from the radiant electrical heater during the test.
- (4) Exhaust gas flow shall be adjusted to  $0.024 \text{ m}^3/\text{s} \pm 0.002 \text{ m}^3/\text{s}$ .
- (5) The surfaces of each specimen shall be covered by the radiation shield to prevent the specimen from radiated until the test begins.
- (6) The ignition plug shall be set at a predetermined position prior to moving the radiation shield.

#### 5. Measurement

- (1) Concentrations of oxygen, carbon monoxide, and carbon dioxide shall be measured at an interval of less than 5 seconds.
- (2) Heat release rate ( $\dot{q}$ ) shall be calculated by the following equation:

$$\dot{q} = \frac{1.10E(X^{0}_{O_2} - X_{O_2})}{(1.105 - 1.5X_{O_2})} \dot{V}_{298}$$

where

$$\dot{V}_{298} = C(\Delta p \cdot T_e)^{1/2} / 350 \quad (\text{flow in the duct at } 25^\circ\text{C})$$

$$E = 17.2 \times 10^3 \text{ kJ/m}^3$$

$X^0_{O_2}$ : average value of oxygen concentration as identified by the one minute baseline measurement

$X_{O_2}$ : measured value of oxygen concentration during the test

Heat release rate per unit area ( $\dot{q}''$ ) shall be:

$$\dot{q}'' = \dot{q} / A_s$$

where

$A_s$ : initial exposure area of the specimen ( $0.0088 \text{ m}^2$ )

$C$  (orifice coefficient) shall be calculated from the oxygen concentration ( $X_{O_2}$ ) and differential pressure ( $\Delta p$ ) when a flow of methane whose heat release rate is equivalent to  $q_b = 5 \text{ kW} \pm 0.5 \text{ kW}$  as measured in accordance with the provision above in 5. under the predetermined exhaust flow.

$$C = q_b / (\Delta h_c / r_o \times 1.10)(T_e / \Delta p)^{1/2} (1.105 - 1.5X_{O_2}) / (0.2095 - X_{O_2})$$

$q_b$ : heat release rate of methane supplied

$\Delta h_c / r_o$ :  $12.54 \times 10^3 \text{ kJ/kg}$  for methane

$T_e$ : gas temperature in exhaust duct (measured near the bi-directional probe)

## 6. Judgment

If a specimen satisfies the following criteria as the result of the test, the product shall be judged acceptable:

- (1) The total heat released in the duration of 10 minutes from the start of heating shall be 8 MJ/m<sup>2</sup> or under.
- (2) Any cracking or holes that penetrate to the rear side which are harmful in terms of fire preventive performance in the duration of 10 minutes from the start of heating shall not be observed.
- (3) The maximum heat release rate shall not exceed 200 kW/m<sup>2</sup> for over 10 seconds in the duration of 10 minutes from the start of heating.

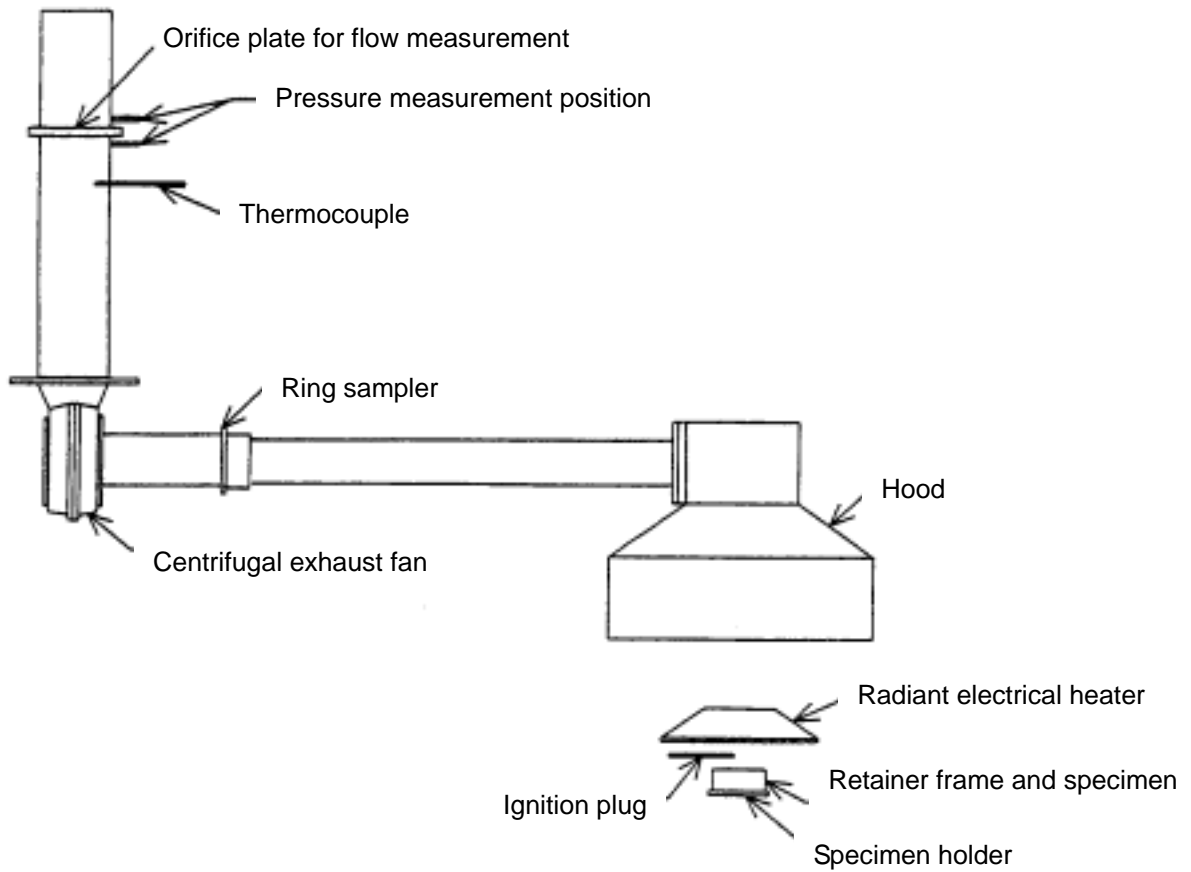

**Attached Fig. 1 Schematic diagram of test equipment (unit: mm)**

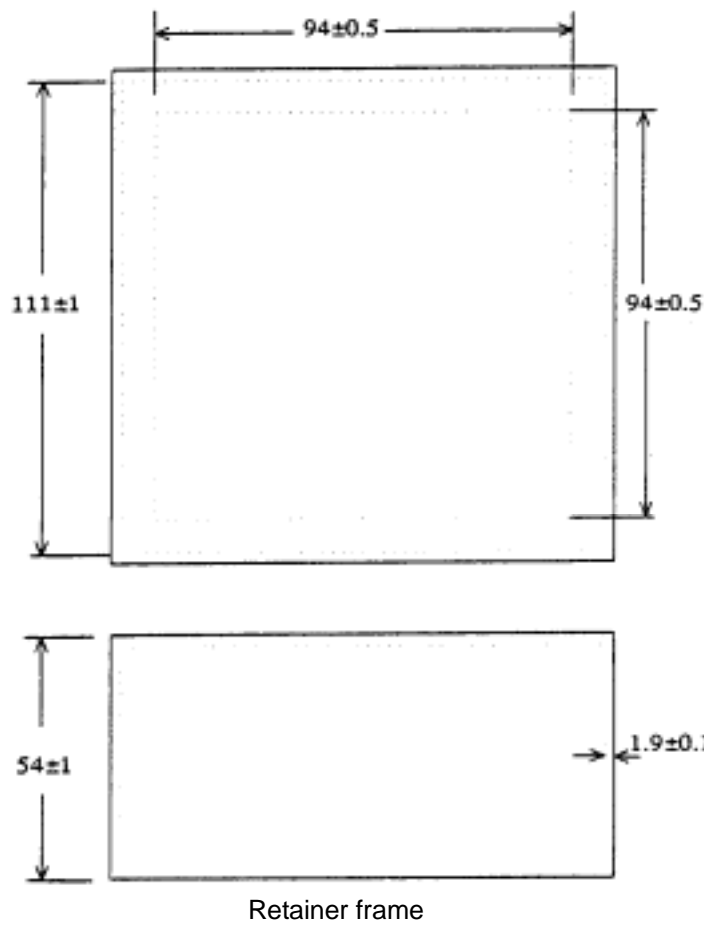
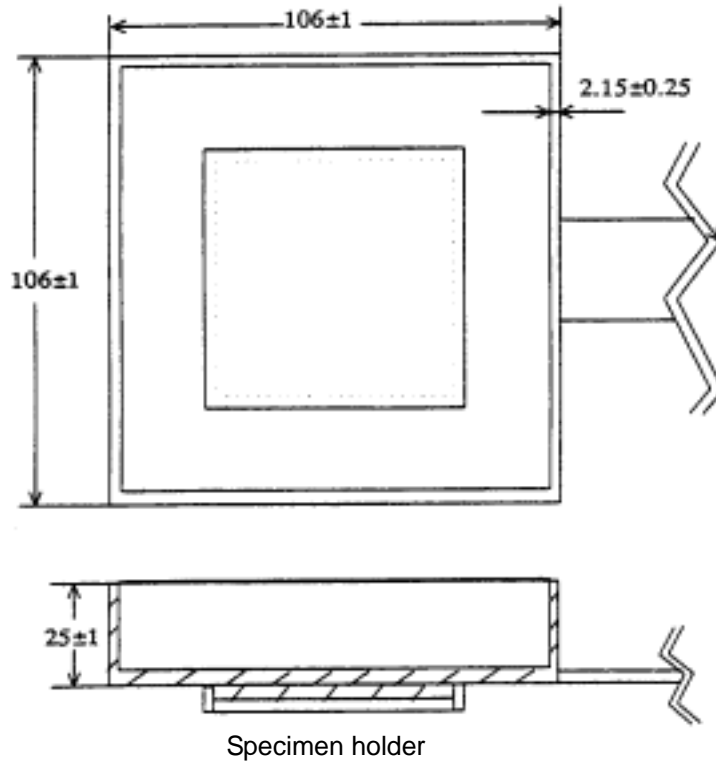

Attached Fig. 2 Specimen holder and retainer frame (unit: mm)

## 4.12 Fire-retardant performance test and evaluation method

Performance evaluation required by Clause 6, Article 1, Order (Fire Retardant Materials) shall be conducted by the following test and evaluation procedure.

### 4.12.0 Scope

This evaluation shall be applied to noncombustible materials and quasi-noncombustible materials (hereinafter defined as those without any facing, dressing, or decoration on the surface) and fire retardant materials (hereinafter defined as those without any facing, dressing, or decoration on the surface) with some facing, dressing, or decoration (defined as surface treatment, such as coating, applied on the surface for the purpose of improving design or appearance) applied on their base materials, whose total mass of organic compounds of the surface-treated layer (including adhesive, if adhesive is used) is 200 g/m<sup>2</sup> or under for base materials of noncombustible materials and 100 g/m<sup>2</sup> or under for base materials of quasi-noncombustible materials and fire retardant materials, or in case some wooden material (such as base paper for board of gypsum board) is already applied onto the surface of that base material, whose the total mass of all organic compounds (including adhesive, if adhesive is used) including the wooden material part is 400 g/m<sup>2</sup> or under.

### 4.12.1 Heat release test and evaluation procedure

#### 1. General

When a specimen is given for a heat release test, such a specimen shall be prepared as specified in 2. and measured as specified in 5. by using the test equipment as specified in 3. under the test condition as specified in 4. If the measurement result satisfies the judgment criteria as provided for in 6., the specimen shall be judged as classified.

#### 2. Specimen

- (1) A specimen, which will be tested as specified, shall have the material and composition representing that of the actual product.
- (2) Specimens shall be basically sampled from the actual product provided that if it is technically difficult to cut out a specimen from the actual product, a specimen shall be prepared to have the material composition, density, and other major conditions so contained or arranged as to allow the performance of the actual product to be properly evaluated.
- (3) The number of specimens shall be three.

- (4) Each specimen shall be a square with each side measuring  $99 \text{ mm} \pm 1 \text{ mm}$  in length and be not higher than 50 mm.
- (5) The thickness and height of each specimen shall be adjusted as shown by a) to d) as follows:
- a) In case the thickness of the product to be tested varies depending on part, the thinnest part shall be used for the test. Providing that in case such thinnest part is certified by the results of a noncombustibility test separately conducted by a certified evaluation institute to be appropriately noncombustible, the thickest part shall be used for the test.
  - b) In case the thickness of the thinnest part of any product to be tested is 50 mm or under, that product having the thinnest part shall be used for the test.
  - c) In case the thickness of the thinnest part is over 50 mm, the rear side of the specimens, which is generally very unlikely to be exposed to flames, shall be properly shaved to adjust the height so as not to create any situation that benefits fire preventive performance of the product. This adjustment may include an arrangement that makes the total mass of organic compounds contained in the specimens become the maximum.
  - d) In case the surface of the product is irregular due to surface treatment, the specimen shall be prepared so as to make the thinnest part become the central part of the specimen.
- (6) For those surface finish materials, such as wall paper or paint, designed to make the surface look good, which are used as surface facing materials for a number of setting bed materials (herein “base materials”) and produced as integral parts of such base materials, specimens of these products shall be prepared by the following rules from a) to c):
- a) Specimens shall be identical to the actual product in terms of base material and manufacturing method.
  - b) Specimens shall be composed of base materials which are the thinnest.
  - c) In case the product has two or more base materials, the following base material shall be treated as the standard one and applied to preparation of specimens:
    - 1) In case two or more noncombustible materials, excluding metal panels, are used as base materials:

Gypsum board, 12.5 mm thick (noncombustible)

- 2) In case two or more noncombustible materials, excluding metal panels (including steel panels) and gypsum board (noncombustible), are used as base materials:

Fiber-reinforced calcium silicate board (noncombustible) with a nominal thickness of 10 mm or under and a specific gravity of 0.8

- 3) In case metal panels, including steel panels, are used as base materials:

Galvanized steel panels with a (original plate) thickness of 0.27 mm

- 4) In case two or more kinds of quasi-noncombustible materials are used as base materials:

Gypsum board, 9.5 mm thick (quasi-noncombustible)

- 5) In case two or more fire retardant materials are used as base materials:

Fire retardant plywood panels, 5.5 mm thick (fire retardant)

- (7) For those finish materials, such as wall paper or paint, which are applied to setting beds at a site, specimens of these products shall be prepared by the following rules a) to c):

- a) Specimens shall be representing the actual product in terms of base material used onsite and manufacturing method practiced onsite.
- b) Specimens shall be composed of base materials which are the thinnest.
- c) In case there are two or more kinds of base materials used onsite, the following base material shall be treated as the standard one and applied to preparation of specimens:

- 1) In case two or more noncombustible materials, excluding metal panels, are used as base materials:

Gypsum board, 12.5 mm thick (noncombustible)

- 2) In case two or more noncombustible materials, excluding metal panels (including steel panels) and gypsum board (noncombustible), are used as base materials:

Fiber-reinforced calcium silicate board (noncombustible) with a nominal thickness of 10 mm or under and a specific gravity of 0.8

- 3) In case metal panels, including steel panels, are used as base materials:

Galvanized steel panels with a (original plate) thickness of 0.27 mm

- 4) In case two or more kinds of quasi-noncombustible materials are used as base materials:

Gypsum board, 9.5 mm thick (quasi-noncombustible)

- 5) In case two or more fire retardant materials are used as base materials:

Fire retardant plywood panels, 5.5 mm thick (fire retardant)

- (8) Specimens shall be conditioned to have a constant mass at temperatures of  $23^{\circ}\text{C} \pm 2^{\circ}\text{C}$  and a relative humidity of  $50\% \pm 5\%$  before the test.

### 3. Test Equipment

- (1) The test equipment shall consist of a cone-shaped electrical heater, ignition plug, radiation shield, specimen holder, gas analyzer, exhaust system designed to measure gas flow, and heat flux meter (Attached Fig. 1).
- (2) The radiant electrical heater shall be capable of delivering a irradiance of  $50 \text{ kW/m}^2$  uniformly over the surfaces of the specimen.
- (3) The radiation shield shall be capable of protecting the specimen from irradiance before the beginning of the test.
- (4) The specimen holder shall have the shape of square pan with an opening of  $106 \text{ mm} \pm 1 \text{ mm}$  at the top, and a depth of  $25 \text{ mm} \pm 1 \text{ mm}$ . The holder shall be constructed of stainless steel with a thickness of  $2.15 \text{ mm} \pm 0.25 \text{ mm}$ . On top of it, there shall be a retainer frame. The frame shall be constructed with a thickness of  $1.9\text{mm} \pm 0.1\text{mm}$  in the shape of a box with an inside dimension of  $111 \text{ mm} \pm 1 \text{ mm}$  and a height of  $54\text{mm} \pm 1\text{mm}$ . The opening for the specimen face shall be  $94\text{mm} \pm 0.5\text{mm}$  square as shown in Attached Fig.2.
- (5) The exhaust system shall be consist of a centrifugal exhaust fan rated for the operating temperature, a hood, intake and exhaust ducts, and an orifice plate flow meter. The distance between the bottom of the hood and the surface of the specimen shall be 210

mm  $\pm$  50 mm. The exhaust system shall be capable of developing flows up to 0.024 m<sup>3</sup>/s. For measurement of the exhaust flow, a restrictive orifice with an internal diameter of 57 mm  $\pm$  3 mm shall be located between the hood and the duct. For sampling of exhaust gas, a ring sampler with 12 holes, whose diameter is 2.2 mm  $\pm$  0.1 mm in inner diameter, shall be installed at a position 685 mm  $\pm$  15 mm from the hood in such an orientation that faces the opening to the direction reverse to the flow of exhaust. Temperature of exhaust gas shall be measured at a point 100 mm  $\pm$  5 mm upstream the orifice at the center of the exhaust duct. The restrictive orifice shall be installed at a position where the measurement will not be affected by the flow.

- (6) The gas analyzer shall be capable of continuously measuring concentrations of oxygen, carbon monoxide, and carbon dioxide in the exhaust gas.
- (7) The ignition plug shall be powered from a 10 kV transformer, induction coil system, etc. The ignition plug shall have a gap of 3 mm  $\pm$  0.5 mm. The electrode's length and location of ignition plug shall be located 13 mm  $\pm$  2 mm on the central axis of the specimen unless otherwise specified.
- (8) The heat flux meter shall be of the Schmidt Boelter type with a design range of 100 kW/m<sup>2</sup>  $\pm$  10 kW/m<sup>2</sup>. The target receiving the heat shall be circular of 12.5 mm in a diameter, with surface emissivity being 0.95  $\pm$  0.05.

#### 4. Test Conditions

- (1) The test time shall be 5 minutes starting from the irradiation of radiation heat onto the specimen surface and the simultaneous generation of electric sparks provided that the measurement may be terminated when it is clearly indicated that no more continuation of burning is possible.
- (2) Each specimen shall be wrapped up both in the side and rear by a sheet of aluminum foil measuring 0.025 mm or more and 0.04 mm or less in thickness. Then, inorganic textile (nominal thickness of 13 mm and a density of 65 kg/m<sup>3</sup>) shall be filled into the rear side and then the entire specimen shall be pressed into the specimen holder.
- (3) The irradiance of 50 kW/m<sup>2</sup> shall be applied to the surface of the specimen from the radiant electrical heater during the test.
- (4) Exhaust gas flow shall be adjusted to 0.024 m<sup>3</sup>/s  $\pm$  0.002 m<sup>3</sup>/s.
- (5) The surfaces of each specimen shall be covered by the radiation shield to prevent the specimen from radiated by heater until the test begins.

- (6) The ignition plug shall be set at a predetermined position prior to moving the radiation shield.

## 5. Measurement

- (1) Concentrations of oxygen, carbon monoxide, and carbon dioxide shall be measured at an interval of less than 5 seconds.
- (2) Heat release rate ( $\dot{q}$ ) shall be calculated by the following equation:

$$\dot{q} = \frac{1.10E(X^{0}\text{O}_2 - X_{\text{O}_2})}{(1.105 - 1.5X_{\text{O}_2})} \dot{V}_{298}$$

where

$$\dot{V}_{298} = C(\Delta p \cdot T_e)^{1/2} / 350 \quad (\text{flow in the duct at } 25^\circ\text{C})$$

$$E = 17.2 \times 10^3 \text{ kJ/m}^3$$

$X^{0}\text{O}_2$ : average value of oxygen concentration as identified by the one minute baseline measurement

$X_{\text{O}_2}$ : measured value of oxygen concentration during the test

Heat release rate per unit area ( $\dot{q}''$ ) shall be:

$$\dot{q}'' = \dot{q} / A_s$$

where

$A_s$ : initial exposure area of the specimen (0.0088 m<sup>2</sup>)

$C$  (orifice coefficient) shall be calculated from the oxygen concentration ( $X_{\text{O}_2}$ ) and differential pressure ( $\Delta p$ ) when a flow of methane whose heat release rate is equivalent to  $q_b = 5 \text{ kW} \pm 0.5 \text{ kW}$  as measured in accordance with the provision above in 5. under the predetermined exhaust flow.

$$C = q_b / (\Delta h_c / r_o \times 1.10)(T_e / \Delta p)^{1/2} (1.105 - 1.5X_{\text{O}_2}) / (0.2095 - X_{\text{O}_2})$$

$q_b$ : heat release rate of methane supplied

$\Delta h/r_o$ :  $12.54 \times 10^3 \text{ kJ/kg}$  for methane

$T_e$ : gas temperature in exhaust duct (measured near the bi-directional probe)

## 6. Judgment

If a specimen satisfies the following criteria as the result of the test, the product shall be judged acceptable:

- (1) The total heat released in the duration of 5 minutes from the start of heating shall be 8 MJ/m<sup>2</sup> or under.
- (2) Any cracking or holes that penetrate to the rear side which are harmful in terms of fire preventive performance in the duration of 5 minutes from the start of heating shall not be observed.
- (3) The maximum heat release rate shall not exceed 200 kW/m<sup>2</sup> for over 10 seconds in the duration of 5 minutes from the start of heating.

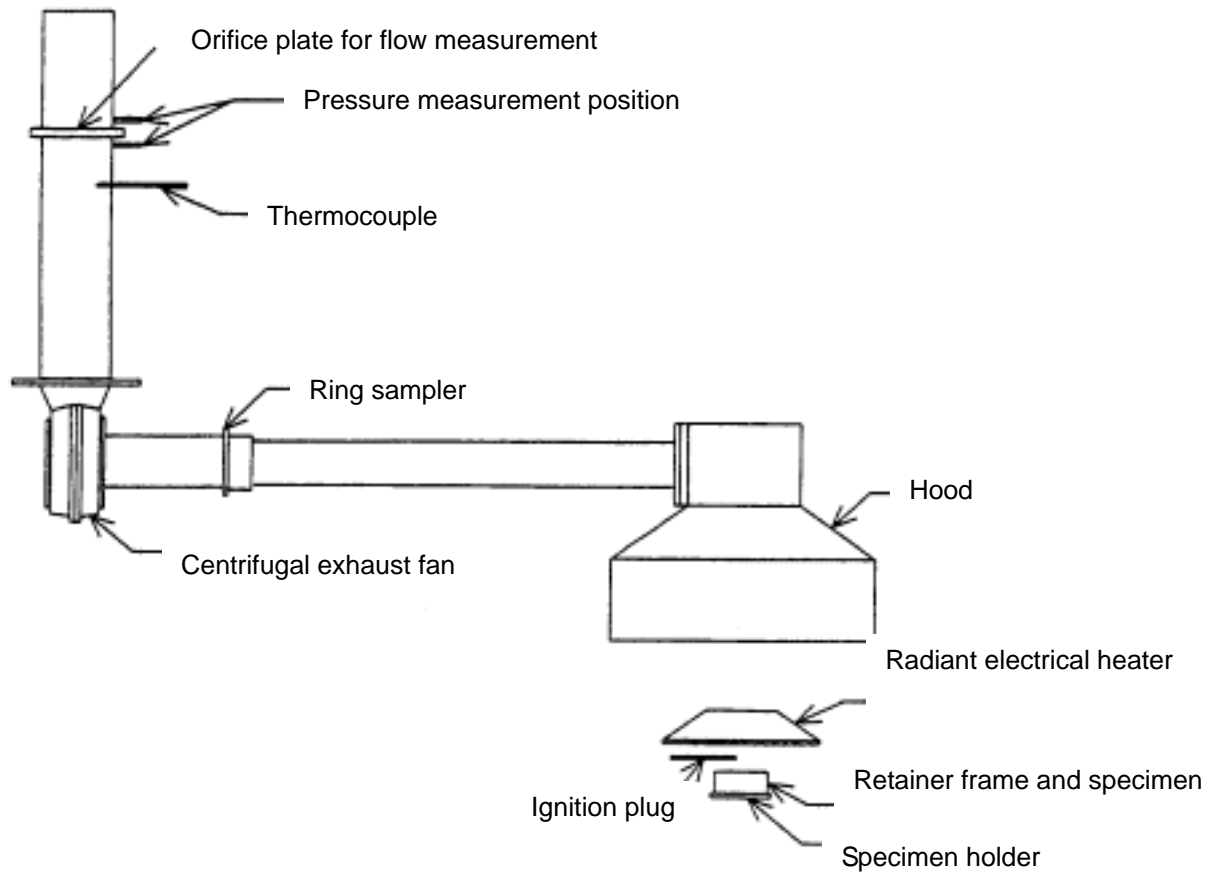

**Attached Fig. 1 Schematic diagram of test equipment (unit: mm)**

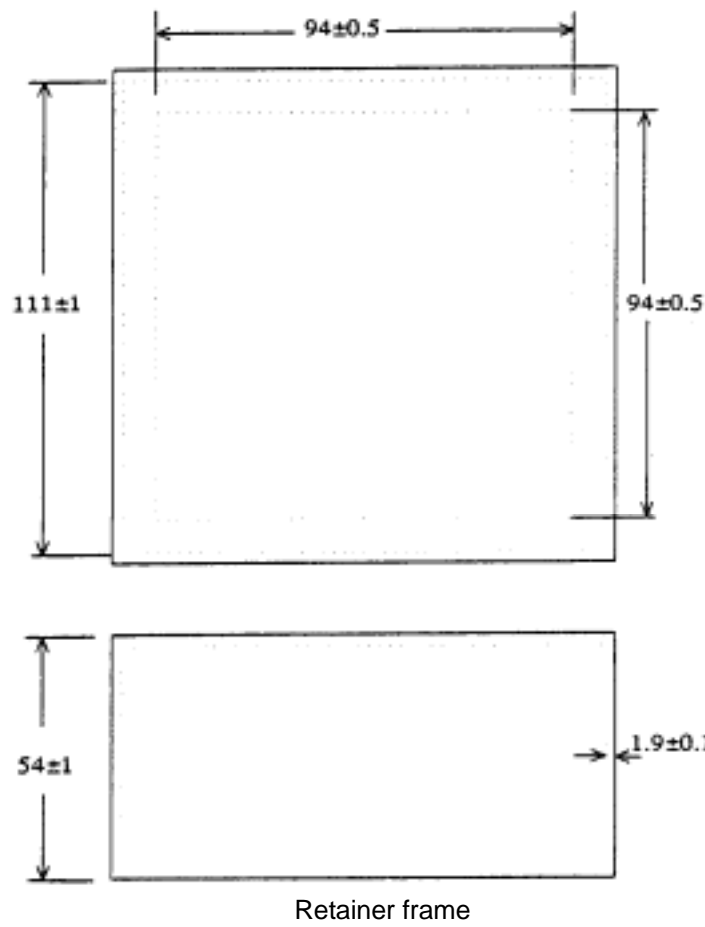
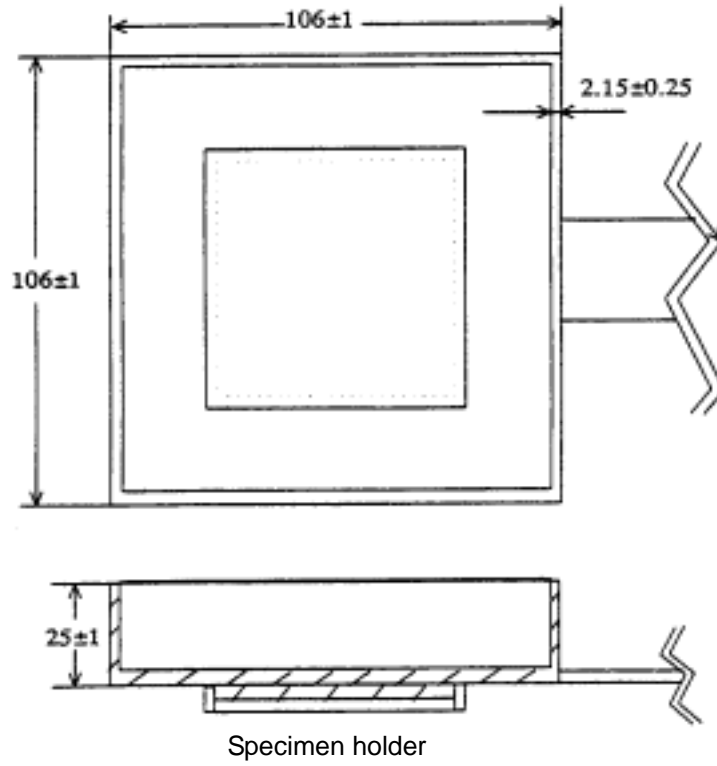

Attached Fig. 2 Specimen holder and retainer frame (unit: mm)

## 5. Performance evaluation report

A Performance Evaluation Report shall describe the following contents. The form and other conditions of the Report shall be separately determined.

- (1) Name of evaluation organization, evaluation number, and evaluation completion date
- (2) Classification of performance evaluation
- (3) Evaluation report (outline of test result, discussion, and summary of evaluation)
- (4) Applicant (company, representative, and address)
- (5) Subject (construction method or name of building material)
- (6) Structural sketch (attachment)
- (7) Specifications of component materials (attachment)
- (8) Standard construction method (attachment)
- (9) Test report (attachment)

#### 4.12.2 Model box test and evaluation procedure

##### 1. General

Model box tests shall be conducted on a set of specimens prepared as specified in 2, using equipment as specified in 3 under the test conditions specified in 4. The specimens shall be judged as classified if measurements carried out as specified in 5 yield results that satisfy the criteria specified in 6.

##### 2. Specimen

- (1) The materials and composition of the specimens shall be representing those of the actual product.
- (2) Specimens cut from the product shall, in principle, be attached to a steel frame, using nails, etc., at intervals of 150 mm. A steel sheet shall be applied to the back, and the ceiling panel, two side wall panels and rear wall panel of the model box shall be prepared. However, if it would be technically difficult to prepare the specimens by cutting them from the product, the specimens shall be prepared with the same materials, composition, structure and density, etc., as the product so that the performance of the actual product can be appropriately evaluated.
- (3) The number of specimens shall be two.
- (4) Form and dimensions of specimens: The overall size of the panels when assembled in box form and inserted into the combustion chamber shall be 840 mm wide by 1,680 mm long by 840 mm high (inside dimensions) (Figure 13).
- (5) The thickness of the product and the thickness of the specimens shall be adjusted as specified in a) through c) below.
  - a) If the product has multiple thicknesses, the specimen shall, in principle, be based on the smallest thickness. However, if it has been clearly shown based on the results of tests conducted separately by a performance evaluation organization that the product has fire retardant performance in its smallest thickness, the largest thickness shall be used.
  - b) If the smallest thickness of the product is 50 mm or less, the specimen shall, in principle, be based on the product with the smallest thickness.

- c) If the smallest thickness of the product is over 50 mm, the height of the specimen shall, in principle, be adjusted by cutting the reverse side, where there is no risk of exposure to flame, and steps shall be taken to ensure that there is no advantage in terms of fire prevention, such as by ensuring that the specimen includes the maximum amount of organic compounds.
- (6) In the case of products that are used as surface decoration materials consisting of multiple types of base materials (hereinafter referred to as “base materials”) with wallpapers, paints and other decorative finishing materials (hereinafter referred to as “finishing materials”) integrated with the base materials at the manufacturing stage, the specimens shall be prepared using the methods specified in a) through c) below.
- a) The specimens shall, in principle, be prepared using the same base materials and manufacturing methods as the actual products.
- b) The specimens shall be prepared using base materials with the smallest thickness.
- c) If the product has multiple types of base materials, the specimens shall be prepared using standard base materials as specified below.
- ① If multiple types of noncombustible base materials other than sheet metal are used  
Gypsum board (noncombustible) with a thickness of 12.5 mm
- ② If multiple types of noncombustible base materials other than sheet metal (including sheet steel, etc.) and gypsum board (noncombustible) are used  
Fiber-reinforced calcium silicate board (noncombustible) with a nominal thickness not exceeding 10 mm and a specific gravity of 0.8
- ③ If sheet metal (including sheet steel, etc.) is used as the base material  
Galvanized steel sheet with a thickness of 0.27 mm (original sheet)
- ④ If multiple types of quasi-noncombustible materials are used  
Gypsum board (quasi-noncombustible material) with a thickness of 9.5 mm
- ⑤ If multiple types of fire retardant materials are used as base materials  
Fire retardant plywood panels (fire retardant material) with a thickness of 5.5 mm

- (7) Specimens of products used as base materials for wallpapers, paints and other finishing materials applied on construction sites shall be prepared as specified in a) through c) below.
- a) The specimens shall, in principle, be prepared by applying the product to the same base materials as used on construction sites, using the same application methods under the same conditions.
  - b) Steps shall be taken to ensure that the base materials used in the specimens do not impart an advantage in terms of fire prevention, and the specimens shall be prepared with the minimum thickness.
  - c) If multiple types of base materials are used on construction sites, the specimens shall be prepared using standard base materials as specified below.
    - ① If multiple types of noncombustible base materials other than sheet metal are used  
Gypsum board (noncombustible) with a thickness of 12.5 mm
    - ② If multiple types of noncombustible base materials other than sheet metal (including sheet steel, etc.) and gypsum board (noncombustible) are used  
Fiber-mixed calcium silicate board (noncombustible) with a thickness not exceeding 10 mm and a specific gravity of approximately 0.8
    - ③ If sheet metal (including sheet steel, etc.) is used as the base material  
Galvanized steel sheet with a thickness of 0.27 mm
    - ④ If multiple types of quasi-noncombustible materials are used  
Gypsum board (quasi-noncombustible material) with a thickness of 9.5 mm
    - ⑤ If multiple types of fire retardant materials are used as base materials  
Fire retardant plywood panels (fire retardant material) with a thickness of 5.5 mm
- (8) Before testing, the specimens shall be cured until the temperature is  $23^{\circ}\text{C} \pm 2^{\circ}\text{C}$  and the relative humidity is  $50\% \pm 5\%$ .

### 3. Test Equipment

- (1) The combustion chamber shall consist of three rectangular walls and a floor and ceiling and shall have internal dimensions of 1,100 mm  $\pm$  10 mm in width, 1,800 mm  $\pm$  10 mm in length and 1,000 mm  $\pm$  10 mm in height. Before the commencement of the tests, a panel measuring 1,100 mm  $\pm$  10 mm wide by 1,000 mm  $\pm$  10 mm high with an opening measuring 300 mm  $\pm$  10 mm wide by 670 mm  $\pm$  10 mm high shall be attached. The combustion chamber shall be made from fiber-reinforced calcium silicate board (noncombustible) with a thickness of 20 mm  $\pm$  2 mm and a density between 400 kg/m<sup>3</sup> and 900 kg/m<sup>3</sup>.
- (2) The fire source shall be a rectangular propane gas burner with a height of 145 mm and an upper surface made from a porous, non-catalytic substance such as sand measuring 170 mm  $\times$  170 mm. The burner shall be positioned in a corner of the combustion chamber opposite to the wall with the opening, so that two sides of the burner are in contact with the walls of the specimen.
- (3) The exhaust system must be equipped with a centrifugal exhaust fan, hood, vent, exhaust duct, and a bi-directional probe flow meter designed to operate effectively at test temperatures (Figure 5). The exhaust capacity shall be at least 2.0 m<sup>3</sup>/s at the standard temperature and pressure. The bi-directional probe (Figure 6), used to measure the exhaust flow shall be installed about 3300 mm from the hood. The sampling probe used to obtain exhaust gas samples (Figure 7) shall be installed about 3400 mm from the hood with the opening oriented in the opposite direction to the flow. The exhaust gas temperature shall be measured close to the bi-directional probe.
- (4) The gas analyzer shall be capable of continuously measuring concentrations of oxygen, carbon monoxide and carbon dioxide in the exhaust gas as accurately as possible.

### 4. Test Conditions

Heating shall be done by supplying propane gas with a purity of at least 95% to the burner for 5 minutes, with the burner adjusted to provide the heat release rate equivalent to 40 kW based on measurements as specified in 5. The exhaust flow shall be adjusted to 2.0 m<sup>3</sup>  $\pm$  0.2 m<sup>3</sup>/s.

### 5. Measurements

- (1) Concentrations of oxygen, carbon monoxide and carbon dioxide shall be measured at intervals not exceeding 5 seconds.
- (2) The heat release rate ( $\dot{q}$ ) shall be calculated according to the following equation.

$$\dot{q} = E \dot{V}_{298} X_{O_2, i} \{ \Phi / \Phi (\alpha - 1) + 1 \}$$

$$\dot{V}_{298} = 22.4 A (\Delta p / T_e)^{1/2} \quad , \quad \text{(flow in duct at 25oC)}$$

$$\Phi = \frac{X_{O_2, i} (1 - X_{CO_2}) - X_{O_2} (1 - X_{CO_2, i})}{X_{O_2, i} (1 - X_{CO_2} - X_{O_2})}$$

where,

- $E$ : Heat release rate per unit of oxygen consumption per unit of area ( $\text{kJ/m}^3$ ) =  $17200 \text{ kJ/m}^3$
- $\alpha$ : Expansion coefficient resulting from chemical reactions = 1.105
- $A$ : Cross-sectional area of duct ( $\text{m}^2$ )
- $\Delta p$ : Pressure differential measured in 2-way probe (Pa)
- $T_e$ : Gas temperature in exhaust duct (measured near 2-way probe)
- $X_{O_2, a}$ : Mole fraction of oxygen in air (= 0.2095)
- $X_{O_2}$ : Value shown by oxygen analyzer during test (mole fraction)
- $X_{CO_2, i}$ : Initial value shown by carbon dioxide analyzer (mole fraction)
- $X_{CO_2}$ : Value shown by carbon dioxide analyzer during test (mole fraction)

## 6. Judgment

A material shall be judged to be classified if specimens satisfy the following criteria based on the results of heating tests.

- (1) Total heat released for five minutes after the start of heating must not exceed 30 MJ. However, since the contribution from the flame source is 10 MJ, the total heat release must not exceed 40 MJ.
- (2) For five minutes after the start of heating, there must be no cracking or holes through the surface layer that would adversely affect fire preventive performance.
- (3) The maximum heat release rate for five minutes after the start of heating must not exceed 140 kW continuously for 10 seconds or more.

#### 4.12.3 Gas toxicity test and evaluation method

##### 1. General

Gas toxicity tests shall be conducted on specimens prepared as specified in 2, using equipment as specified in 3 under the test conditions specified in 4. The specimens shall be judged to be classified if measurements carried out as specified in 5 yield results that satisfy the criteria specified in 6.

##### 2. Specimens

- (1) The materials and composition of the specimens shall be representing those of the actual product.
- (2) Specimens shall, in principle, be taken from the products. However, if it would be technically difficult to prepare the specimens by taking them from the product, the specimens shall be prepared with the same materials, composition, structure and density, etc., as the product so that the performance of the actual product can be appropriately evaluated.
- (3) Two specimens shall be provided.
- (4) The specimens shall be square, measuring  $220 \text{ mm} \pm 10 \text{ mm}$  on each side, and no more than 15 mm thick.
- (5) The thickness of the product and the thickness of the specimens shall be adjusted as specified in a) through e) below.
  - a) If the product has multiple thicknesses, the specimen shall, in principle, be based on the smallest thickness. However, if it has been clearly shown based on the results of tests conducted separately by a performance evaluation organization that the product has fire retardant performance in its smallest thickness, the largest thickness shall be used.
  - b) If the smallest thickness of the product is 15 mm or less, the specimen shall, in principle, be based on the product with the smallest thickness.
  - c) If the smallest thickness of the product is over 15 mm, the height of the specimen shall, in principle, be adjusted by cutting the reverse side, where there is no risk of exposure to flame, and steps shall be taken to ensure that there is no advantage in

terms of fire prevention, such as by ensuring that the specimen includes the maximum amount of organic compounds.

- e) Thin materials with thicknesses of 5 mm or less shall be adjusted to a thickness of approximately 15 mm, using the standard sheet defined in 4.(1) as a base material.
  - f) If the surface of the product is not smooth, such as when the surface has been processed to create an uneven texture, the specimens should be prepared with the points at which the thickness is smallest at the center.
- (6) In the case of products that are used as surface decoration materials consisting of multiple types of base materials (hereinafter referred to as “base materials”) with wallpapers, paints and other decorative finishing materials (hereinafter referred to as “finishing materials”) integrated with the base materials at the manufacturing stage, the specimens shall be prepared using the methods specified in a) through c) below.
- a) The specimens shall, in principle, be prepared using the same base materials and manufacturing methods as the actual products.
  - b) The specimens shall be prepared using base materials with the smallest thickness.
  - c) If the product has multiple types of base materials, the specimens shall be prepared using standard base materials as specified below.
    - ① If multiple types of noncombustible base materials other than sheet metal are used  
  
Gypsum board (noncombustible) with a thickness of 12.5 mm
    - ② If multiple types of noncombustible base materials other than sheet metal (including sheet steel, etc.) and gypsum board (noncombustible) are used  
  
Fiber-reinforced calcium silicate board (noncombustible) with a nominal thickness not exceeding 10 mm and a density of 0.8
    - ③ If sheet metal (including sheet steel, etc.) is used as the base material  
  
Galvanized steel sheet with a thickness of 0.27 mm (original sheet)
    - ④ If multiple types of quasi-noncombustible materials are used  
  
Gypsum board (quasi-noncombustible material) with a thickness of 9.5 mm

- ⑤ If multiple types of fire retardant materials are used as base materials  
  
Fire retardant plywood panels (fire retardant material) with a thickness of 5.5 mm
  
- (7) Specimens of products used as base materials for wallpapers, paints and other finishing materials applied on construction sites shall be prepared as specified in a) through c) below.
  - a) The specimens shall, in principle, be prepared by applying the product to the same base materials as used on construction sites, using the same application methods under the same conditions.
  - b) Steps shall be taken to ensure that the base materials used in the specimens do not impart an advantage in terms of fire prevention, and the specimens shall be prepared with the minimum thickness.
  - c) If multiple types of base materials are used on construction sites, the specimens shall be prepared using standard base materials as specified below.
    - ① If multiple types of noncombustible base materials other than sheet metal are used  
  
Gypsum board (noncombustible) with a thickness of 12.5 mm
    - ② If multiple types of noncombustible base materials other than sheet metal (including sheet steel, etc.) and gypsum board (noncombustible) are used  
  
Fiber-reinforced calcium silicate board (noncombustible) with a thickness not exceeding 10 mm and a specific gravity of approximately 0.8
    - ③ If sheet metal (including sheet steel, etc.) is used as the base material  
  
Galvanized steel sheet with a thickness of 0.27 mm
    - ④ If multiple types of quasi-noncombustible materials are used  
  
Gypsum board (quasi-noncombustible material) with a thickness of 9.5 mm
    - ⑤ If multiple types of fire retardant materials are used as base materials  
  
Fire retardant plywood panels (fire retardant material) with a thickness of 5.5 mm

- (8) Before testing, the specimens shall be cured until the temperature is  $23^{\circ}\text{C} \pm 2^{\circ}\text{C}$  and the relative humidity is  $50\% \pm 5\%$ .

### 3. Test Equipment

The test equipment shall consist of a furnace, mixing box, animal exposure box, rotary cages and mouse monitors.

- (1) The structure of the furnace shall be as shown in Figure 8. The primary heat source shall be electric heater, and gas burner supplied with a purity of at least 95% propane shall be used as the secondary heat source.
- (2) The specimen surface exposed to heat shall measure 180 mm in width and height.
- (3) The furnace shall be supplied with air at the rate of 3 L/min. from the primary air supply system and 25 L/min. from the secondary air supply system.
- (4) The mixing box shall be configured as shown in Figure 9 and installed as shown in Figure 10.
- (5) The animal exposure box shall be configured as shown in Figure 11, and eight wheels shall be installed as shown in Figure 11. The specimen box shall be positioned in relation to the mixing box as shown in Figure 9.
- (6) The rotary cages shall be configured as shown in Figure 12. In principle, the rotating section shall be made of aluminum with a mass not exceeding 75 g.
- (7) The mouse monitors shall be capable of electrically recording the activity of the mice as they rotate the rotary cages.

### 4. Test Conditions

- (1) A panel of fiber-reinforced calcium silicate board, dried as specified in 2(5) and with a thickness of  $11 \text{ mm} \pm 2 \text{ mm}$  and a density of  $750 \text{ kg/m}^3 \pm \text{kg/m}^3$  (hereinafter referred to as “standard board”) shall be placed in the furnace, which shall be heated initially for 3 minutes using the secondary heat source (propane gas) and then for 3 minutes using the primary heat source (1.5 kW), while it is supplied with air at the rate of 3 L/min. from the primary air supply system and 25 L/min. from the secondary air supply system. The furnace shall be configured so that the exhaust temperatures shown in the following table, as measured using a thermocouple as shown in Figure 8 with an external diameter of 1.5 mm (1.6 mm) (JIS C 1605, sheathed thermocouple, Type K), can be reproduced

with a margin of error within 20°C. However, the exhaust temperature at the start of the test shall be 50°C or less.

Elapsed time (min.)	1	2	3	4	5	6
Exhaust temperature (°C)	70	85	100	140	170	195

- (2) The rear lid shall be opened to allow the exhaust temperature to cool to 50°C or less.
- (3) With the temperature in the specimen box not exceeding 30°C, one mouse (dd or ICR, females, 4-5 weeks old, body weight: 18–22 g) shall be placed in each of the eight rotary cages installed in the specimen box.
- (4) Air shall be supplied at the rates of 3 L/min. from the primary air supply system and 25 L/min. from the secondary air supply system.
- (5) The exhaust rate from the specimen box shall be set at 10 L/min.
- (6) Heat shall initially be applied for 3 minutes from the secondary heat source (LPG), and then for 3 minutes from the primary heat source (1.5 kW).
- (7) After the completion of heating, the supply of air to the furnace and the removal of exhaust from the specimen box shall be cut off.

## 5. Measurement

The time to the incapacitation of each mouse's movement shall be recorded for 15 minutes from the start of heating.

## 6. Judgment

A material shall be judged to be classified if the average time to the termination of mouse activity ( $\overline{X}_s$ ) as calculated using the following equation is 6.8 minutes or more.

$$\overline{X}_s = \overline{X} - \sigma$$

In this equation,  $\overline{X}$  and  $\sigma$  express the following values.

---

$\bar{X}$ : Average time (minutes) to termination of activity by 8 mice (15 minutes if mouse activity does not terminate)

$\sigma$ : Standard deviation (minutes) of time to termination of activity by 8 mice (15 minutes if mouse activity does not terminate)

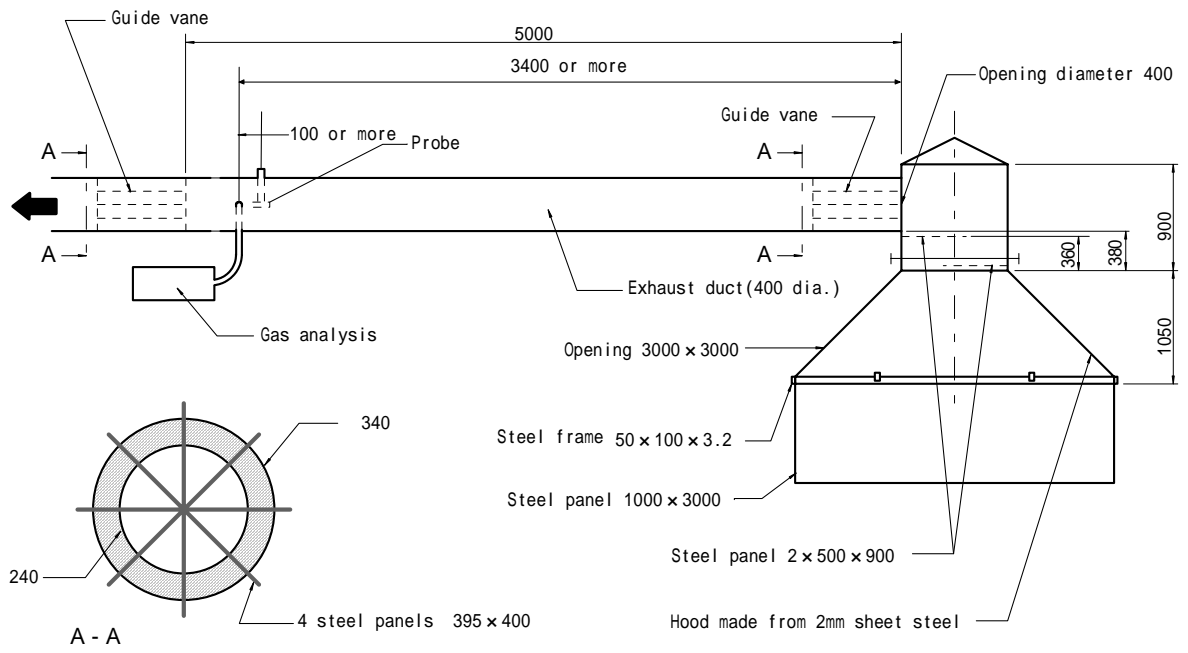

Figure 5: Exhaust System

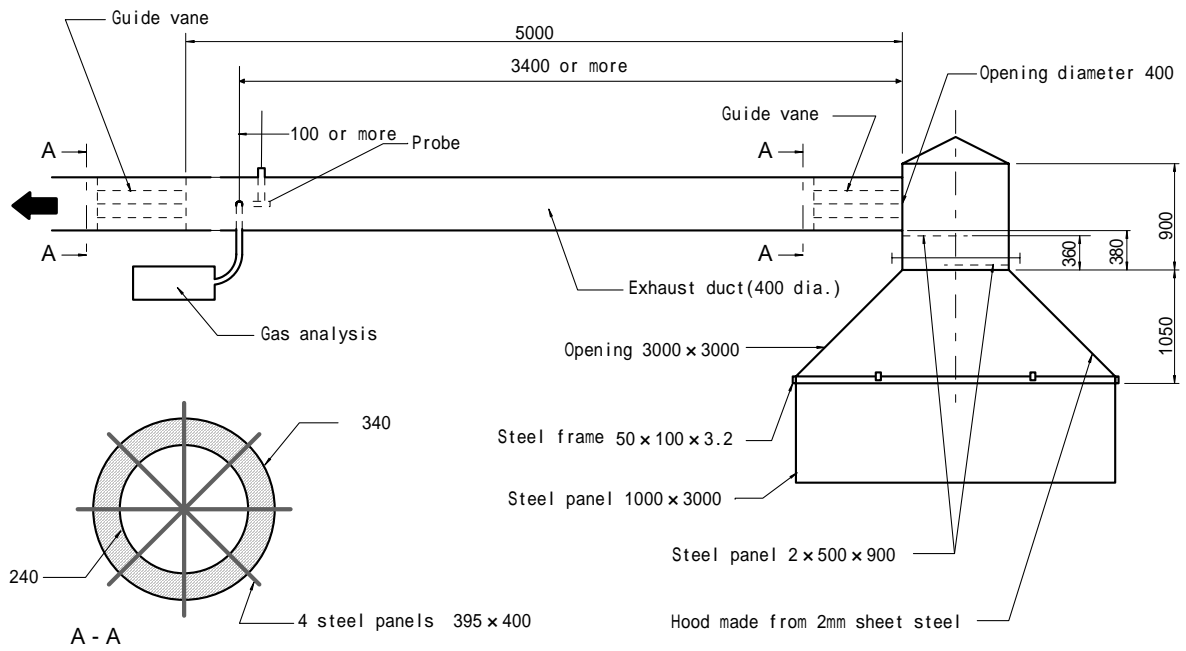

Figure 5: Exhaust System

(Unit: mm)

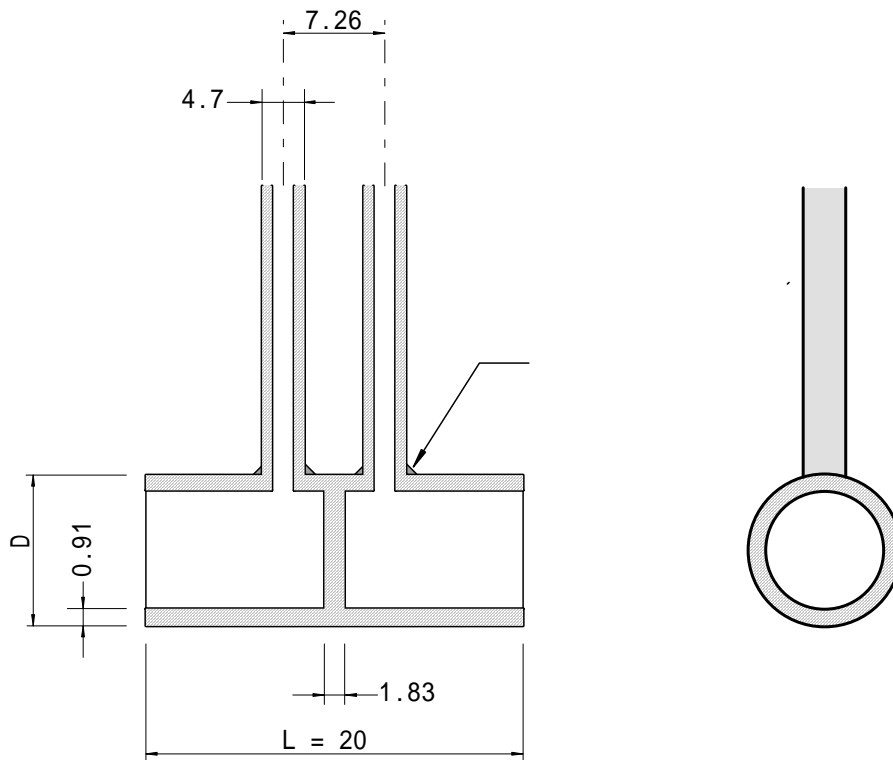

Figure 6: 2-Directional Probe

(Unit: mm)

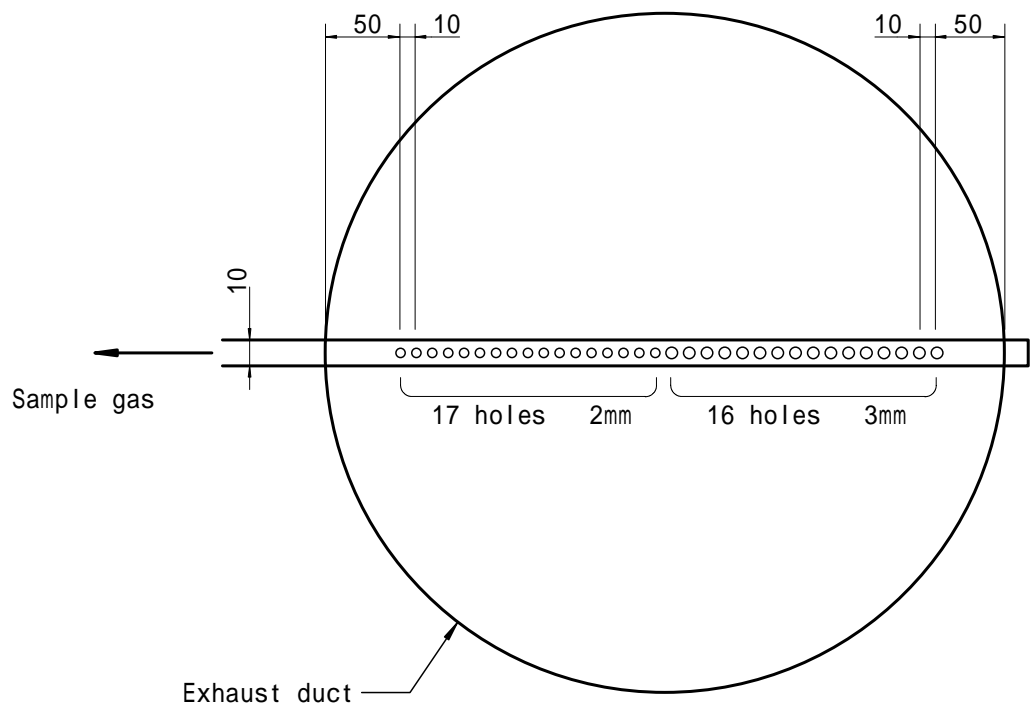

Figure 7: Sampling Probe  
(Unit: mm)

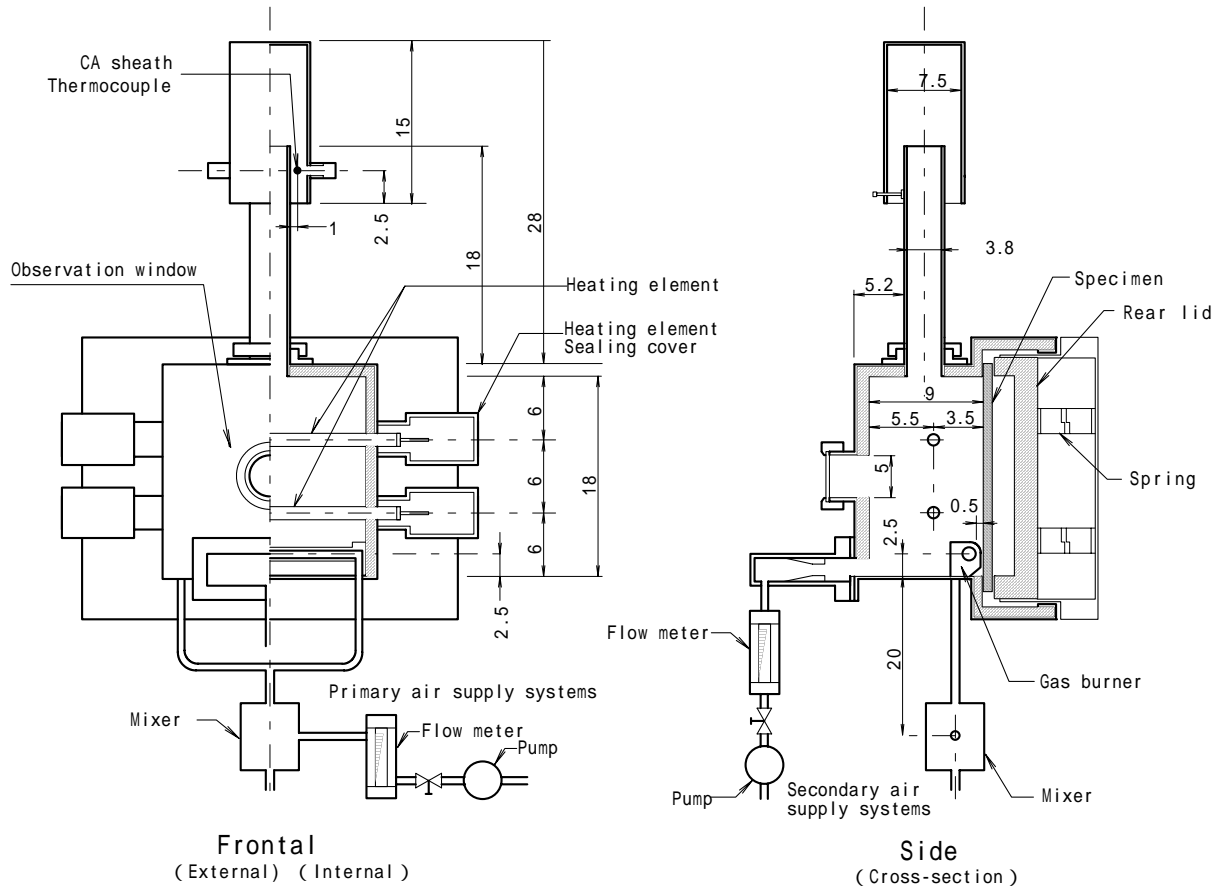

Figure 8: Furnace for Gas Toxicity Test (Unit: cm)

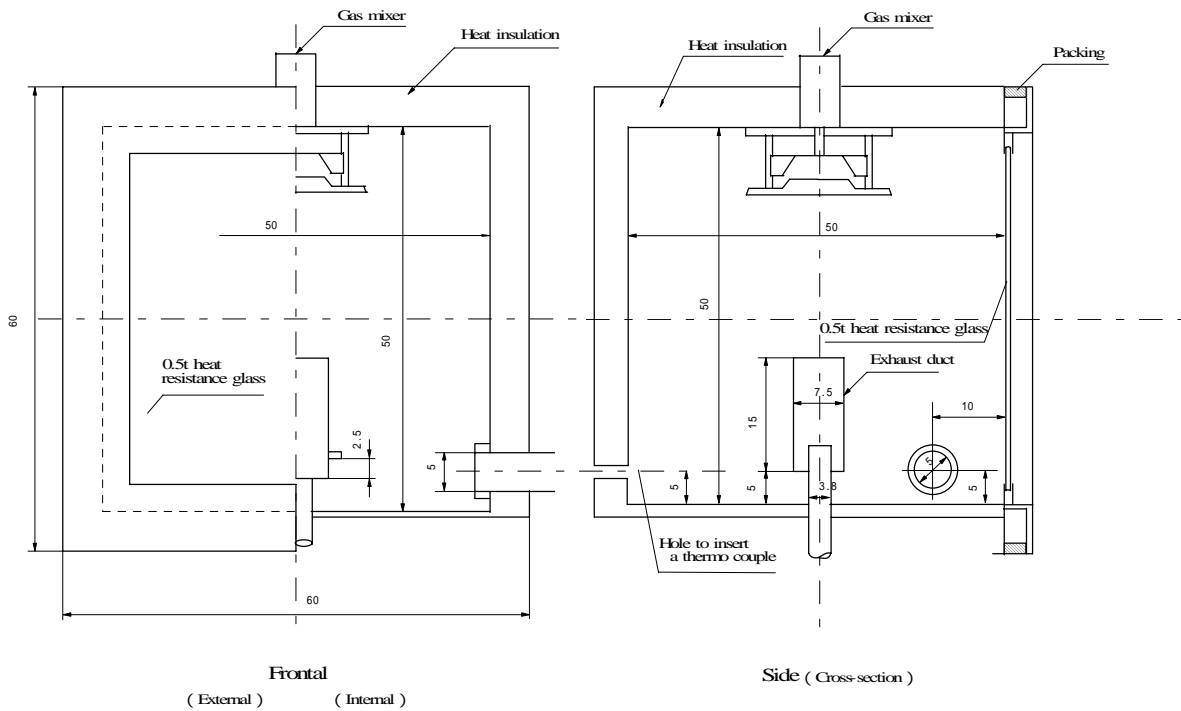

Figure 9: Mixing box (Dimensions in cm)

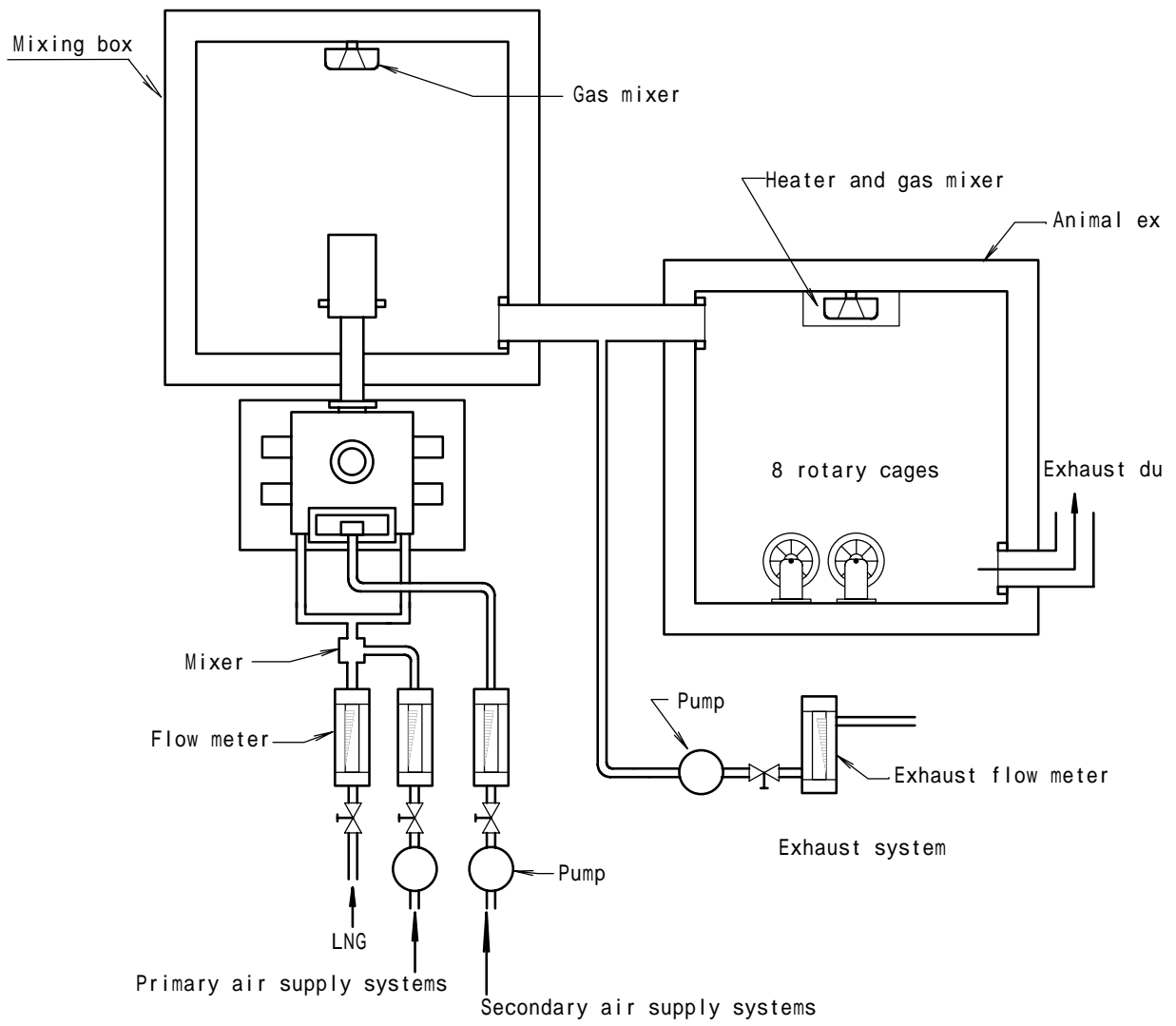

Figure 10 Equipment Flow Chart

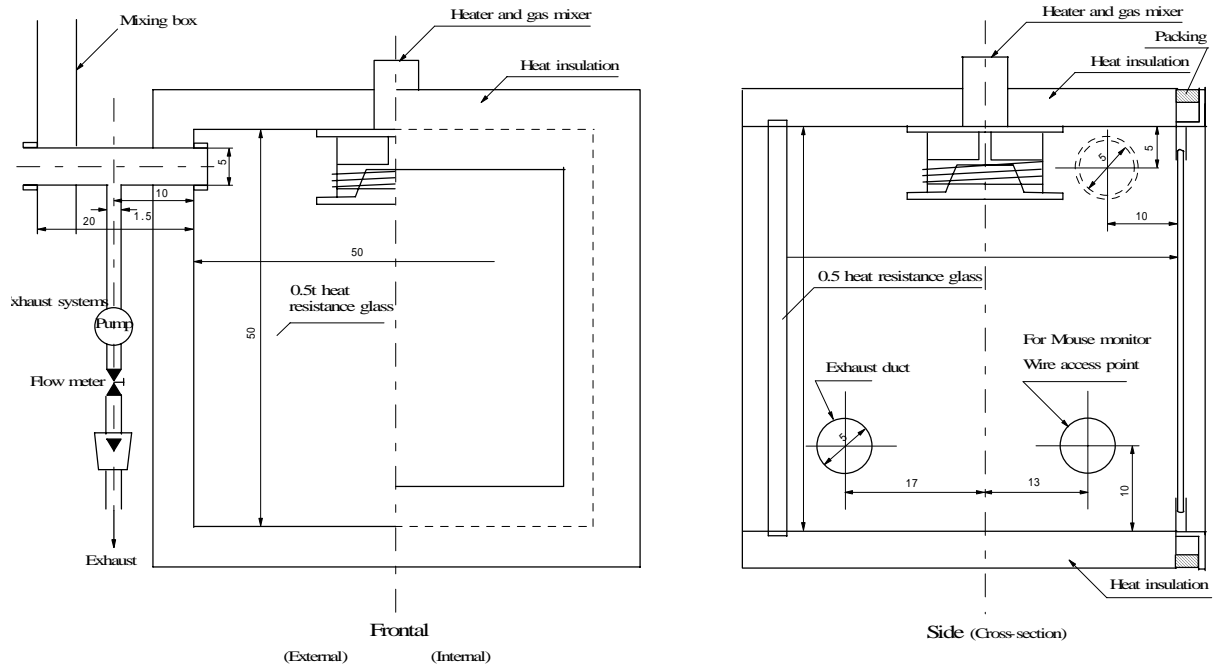

Figure 11: Animal Exposure Box(Unit: cm)

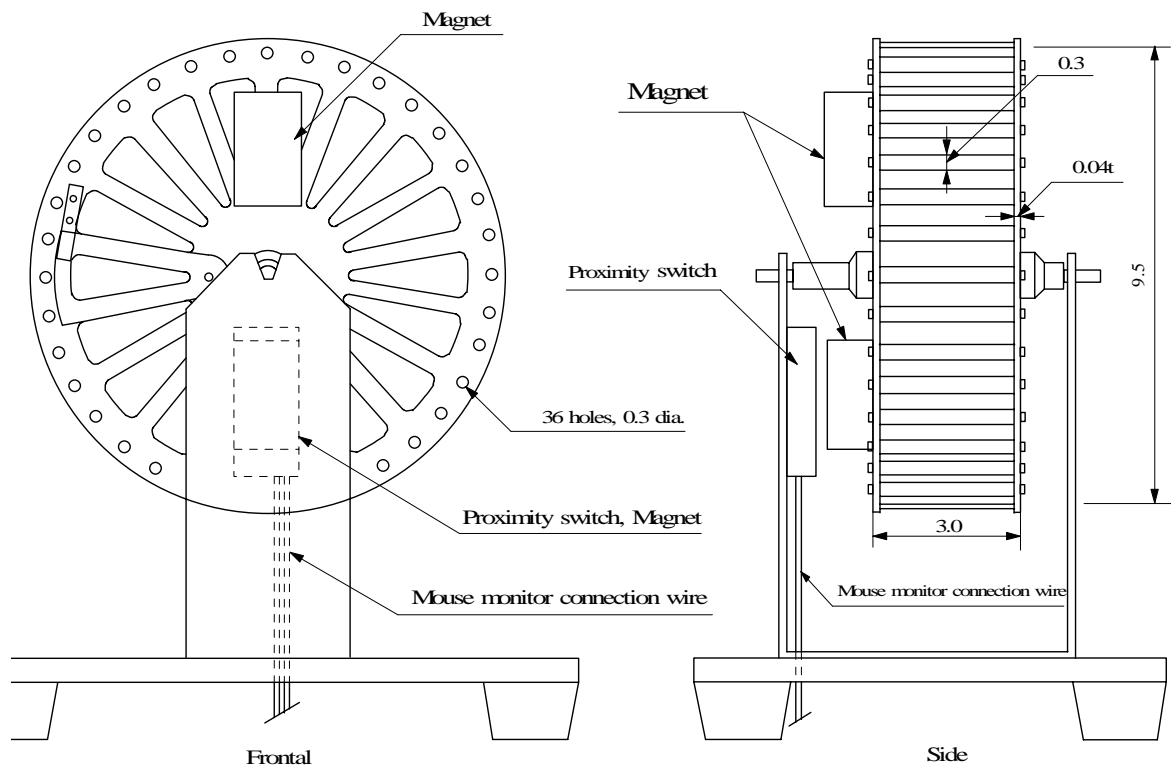

Figure 12: Rotary cages(Unit: mm)

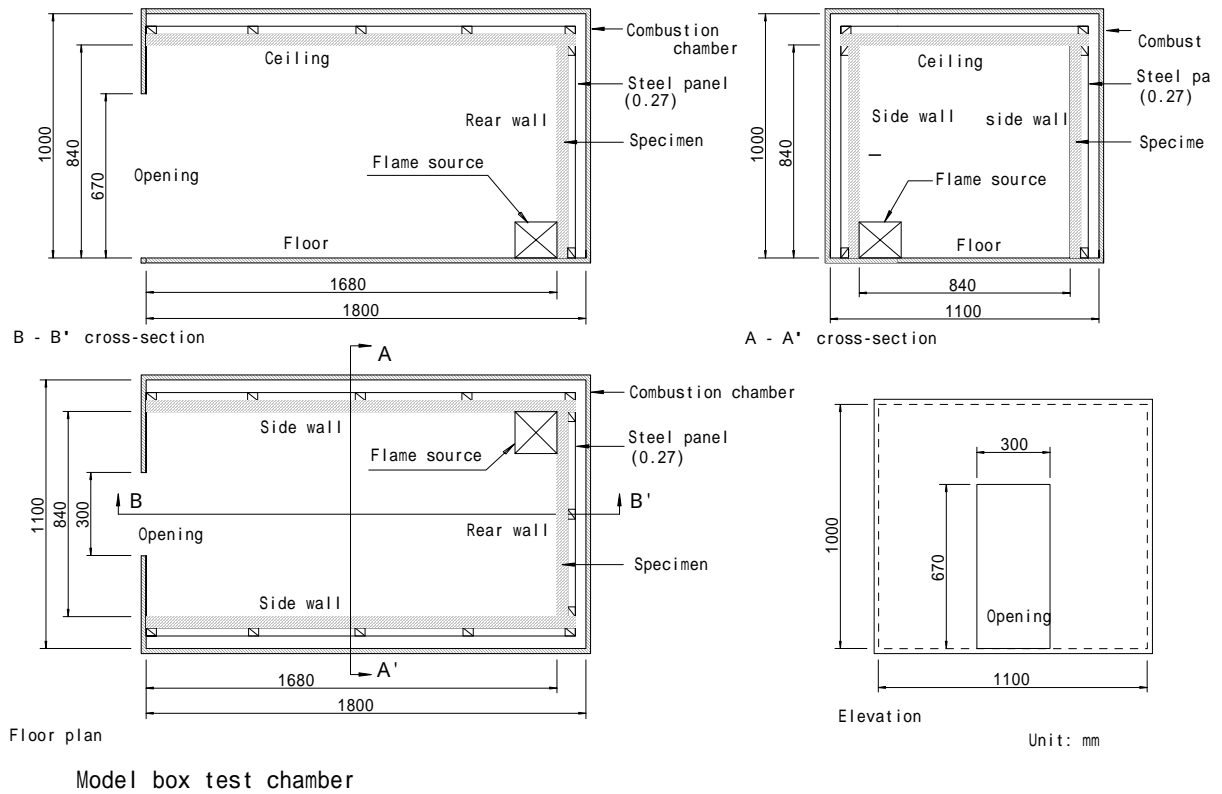

Figure 13: Model Box Test Equipment(Dimensions in mm)

#### 4.13 Testing and Evaluation Procedure for Ember Ignition Performance of Roofing Materials

Performance evaluations required by the provision of Article 22 Paragraph 1 (Roofs) and Article 63 (Roofs) of the Law shall be conducted using the following test and evaluation procedure.

##### 1. General

The fire resistive performance of a roof shall be classified if tests using specimens as specified in 2 and test equipment as specified in 3 under the conditions specified in 4 yield measurements as specified in 5 that satisfy the criteria specified in 6.

##### 2. Specimens

- (1) The materials and composition of the specimens shall be representing those of the actual product.
- (2) Specimens shall be prepared by cutting materials from the product and reproducing their actual installation. However, if it would be technically difficult to prepare the specimens by cutting them from the product, the specimens shall be prepared with the same materials, composition, structure and density, etc., as the product so that the performance of the actual product can be appropriately evaluated.
- (3) The number of specimens shall be two.
- (4) The specimens shall be rectangular and measure 1200 mm  $\pm$  100 mm wide by 2000 mm  $\pm$  200 mm long by not exceeding 250 mm high.
- (5) If the roof structure is installed using support members, etc. (rafters, etc.), the specimens shall be prepared according to actual construction conditions with regard to the parts from the support members to the upper roofing materials. However, if there are multiple types of roof structures, the specimens shall be prepared using the following standard support members and structures.

###### a) Wooden structures

The rafters shall be specified on the basis of the smallest actual rafters.

###### b) Reinforced concrete

ALC panels with a thickness of 50 mm

c) Steel-frame

Lightweight channel steel or lip channel steel between 50 mm and 100 mm

- (6) Sheathing shall be of the same type as the product and have the smallest thickness. However, if the sheathing is made from plywood, particle board or OSB, the material from among these three types that has the smallest thickness shall be used.
- (7) If actual construction results in joints or other points of vulnerability in terms of fire prevention (gaskets, sealing materials, other organic joiners, etc.), brands shall be positioned as much as possible on these points of vulnerability in the specimens.
- (8) Specimens shall be kept in air-dry conditions (e.g. minimum temperature: 15°C, maximum relative humidity: 75%).

### 3. Test Equipment

The test equipment shall consist of a blower, a specimen stand, and a gas burner to ignite brabds.

(1) Blower

The blower shall be capable of applying an air flow across the surface of specimens as unifrom as possible in a horizontal direction. The vent shall be at least 250 mm high and 1000 mm wide, and the nozzle shall be at least 1200 mm long. The blower shall be designed to distribute the air flow uniform without turbulence across the surface of the specimens.

(2) Specimen Stand

The stand shall be configured to allow the angle of incline to be set at any position between 0° and 30°, with canopies, etc., to prevent the air flow from being carried to the lower surface of the specimens. However, the stand shall not be configured to prevent items being blown or falling from the roof surface.

(3) Gas burner

The heat source used to ignite the brands shall be propane gas, and the burner shall be configured to produce a flame of sufficient size to ensure that entire ember is enclosed within the flame, and to provide a uniform temperature ( $900^{\circ}\text{C} \pm 50^{\circ}\text{C}$ ) at a distance of  $60 \text{ mm} \pm 5 \text{ mm}$  above the top of the burner.

#### 4. Test Conditions

- (1) The wind speed, measured to the accuracy of  $0.1 \text{ m/s}$  or less, at a standard point (Figure 1) above the surface of a panel fiber-mixed calcium silicate board with a thickness of  $12 \text{ mm} \pm 2 \text{ mm}$ , a density of  $900 \text{ kg/m}^3 \pm 100 \text{ kg/m}^3$  and an overall size of  $1200 \text{ mm} \times 1200 \text{ mm}$  (hereinafter referred to as the “standard panel”) installed in place of the specimen shall satisfy the following values at each angle of incline.

The wind speed shall be  $3.0 \text{ m/s} \pm 0.5 \text{ m/s}$  at a point  $500 \text{ mm}$  and  $505 \text{ mm}$  from the bottom edge of the upwind side of the standard panel, and at a total of six points: at heights of between  $100 \text{ mm}$  and  $105 \text{ mm}$  and between  $200 \text{ mm}$  and  $205 \text{ mm}$  above the symmetrical axis of the long side of the panel, and between  $300 \text{ mm}$  and  $305 \text{ mm}$  to the left and to the right of the symmetrical axis.

The wind speed shall be between  $2.0 \text{ m/s}$  and  $3.0 \text{ m/s}$  at a point between  $100 \text{ mm}$  and  $105 \text{ mm}$  above a point between  $1700 \text{ mm}$  and  $1705 \text{ mm}$  from the bottom edge of the upwind side of the standard panel, and at three points: on the symmetrical axis of the long side of the panel ( $V_A$ ) and between  $300 \text{ mm}$  and  $305 \text{ mm}$  to the left ( $V_B$ ) and right ( $V_C$ ) of the symmetrical axis.

$$3.0 \text{ m/s} > V_A > 2.0 \text{ m/s}$$

$$V_B = V_C \pm 0.5 \text{ m/s}$$

- (2) Roofs based on the provisions of Article 22 Paragraph 1
  - a) The brands shall be cubes measuring  $40 \text{ mm} \times 40 \text{ mm} \times 40 \text{ mm}$  formed from beech wood with a density of  $560 \text{ kg/m}^3 \pm 50 \text{ kg/m}^3$ , and with grooves about  $3 \text{ mm}$  wide saw kerf in the centers of the top and bottom sides to a depth equivalent to one-half of the thickness of the embers and positioned at right angles to each other. The mass of the embers shall be adjusted to  $33 \text{ g} \pm 5 \text{ g}$  after curing for at least  $24 \text{ hours}$  at a temperature of  $23^{\circ}\text{C} \pm 2^{\circ}\text{C}$  and a relative humidity of  $50\% \pm 5\%$ .
  - b) The specimens shall be placed on the stand, and the stand shall be adjusted to the following angles of incline.

- ① For roofs with angles of incline in a range between 0° and 30°, an angle of 15°
  - ② For roofs with angles in a range from 30° to less than 70°, an angle of 30°
  - ③ For flat roofs, an angle of 0°
- c) The first ember shall be ignited by applying the flame from the burner for one minute to the side of the brand with a straight groove and for one minute to the opposite side. The brand shall then be placed on the specimen at a position 500 mm above the bottom edge of the specimen and 185 mm to the left of the symmetrical axis on the long side.
- d) Two minutes after the placing of the first ember, the second ember shall be ignited using the same procedure and placed at a position 500 mm above the bottom edge of the specimen and 185 mm to the right of the symmetrical axis on the long side, four minutes after the placing of the first ember.
- e) The brands shall be effectively prevented from falling by means of wires, etc., at the designated positions.
- (3) Roofs based on the provisions of Article 63
- a) The brands shall be formed by making rods measuring 19 mm × 19 mm × 80 mm from beech wood with a density of  $560 \text{ kg/m}^3 \pm 50 \text{ kg/m}^3$ , and arranging them in three layers, each layer consisting of three strips of lumber at regular intervals, with the layers positioned at right angles to each other, and fixed using suitable steel nails, etc., to form units (hereinafter referred to as “cribs”) with overall dimensions of 80 mm × 80 mm × 60 mm. The mass of the brands shall be adjusted to  $155 \text{ g} \pm 10 \text{ g}$  (excluding the mass of the fixing pins) after curing for at least 24 hours at a temperature of  $23^\circ\text{C} \pm 2^\circ\text{C}$  and a relative humidity of  $50\% \pm 5\%$ .
- b) The specimens shall be placed on the stand, and the stand shall be adjusted to the following angles of incline.
- ① For roofs with angles of incline in a range between 0° and 30°, an angle of 15°
  - ② For roofs with angles in a range from 30° to less than 70°, an angle of 30°
  - ③ For flat roofs, an angle of 0°
- c) A crib shall be ignited by applying the flame from the burner for one minute to each of the largest sides. The first brand shall then be placed on the specimen.

- d) Two minutes after the placing of the first brand, the crib that will become the second brand shall be ignited using the same procedure and placed on the specimen four minutes after the placing of the first brand.
- e) The brands shall be effectively prevented from falling by means of wires, etc., at the designated positions.

## 5. Measurement

Observations and measurements shall be performed and recorded for 30 minutes between the placing of the first brand to ascertain whether or not there is spreading of fire or other changes along the surface of the specimens, whether or not there are holes burned through the specimens, and whether or not ignition has occurred behind the specimens. However, the progress of fire shall be judged at the leading edge of the fire.

- (1) Spreading of fire or other changes along the surface
  - a) If burning materials scattered or fell from the surface of the specimens, the times at which this occurred
  - b) The maximum extent of burning during the test and the time at which it was reached (length and width)
- (2) Burning through, etc.
  - a) If the specimen burned through, the time at which this occurred
  - b) If burning materials fell from the rear surface of the specimens, the times at which this occurred
- (3) Openings

If a hole measuring more than 10 mm × 10 mm at its largest section is observed, the time when it was formed

## 6. Judgment

- (1) Roofs based on the provisions of Article 22 Paragraph 1

A material shall be classified under Article 109-5 Items 1 and 2 of the Enforcement Order if specimens subjected to heating tests using embers prepared for tests under Article 22 of the Law satisfy the following criteria. Products that satisfy the requirements specified in (a) shall be classified under Article 109-5 Items 1 of the Enforcement Order.

- a) The edge of the fire resulting from combustion of the specimen must not reach the bottom edges of the upwind and downwind sides of the specimen (if the length of the specimen exceeds 2000 mm, a position 2000 mm from the bottom edge on the downwind side shall be treated as the bottom edge) or the left or right edges (if the width of the specimen exceeds 1200 mm, a position 600 mm to the left or right of the symmetrical axis of the long side shall be treated as the edge).
- b) No combustion accompanied by flames must be observed on the rear side of the specimens during the test.
- c) No holes penetrating through the specimen and measuring more than 10 mm × 10 mm at their largest section must be observed, either during the test or during observations after completion of the test.

(2) Roofs based on the provisions of Article 63

A material shall be classified under the Article 136-2-2 Items 1 and 2 of the Enforcement Order if specimens subjected to heating tests using brands prepared for tests under Article 63 of the Law satisfy the following criteria. Products that satisfy the requirements specified in (a) shall be classified under the Article 136-2-2 Item 1 of the Enforcement Order.

- a) The edge of the fire resulting from combustion of the specimen must not reach the bottom edges of the upwind or downwind sides of the specimen (if the length of the specimen exceeds 2000 mm, a position 2000 mm from the bottom edge on the downwind side shall be treated as the bottom edge) or the left or right edges (if the width of the specimen exceeds 1200 mm, a position 600 mm to the left or right of the symmetrical axis of the long side shall be treated as the edge).
- b) No combustion accompanied by flames must be observed on the rear side of the specimens during the test.
- c) No holes penetrating through the specimen and measuring more than 10 mm × 10 mm at their largest section must be observed, either during the test or during observations after completion of the test.

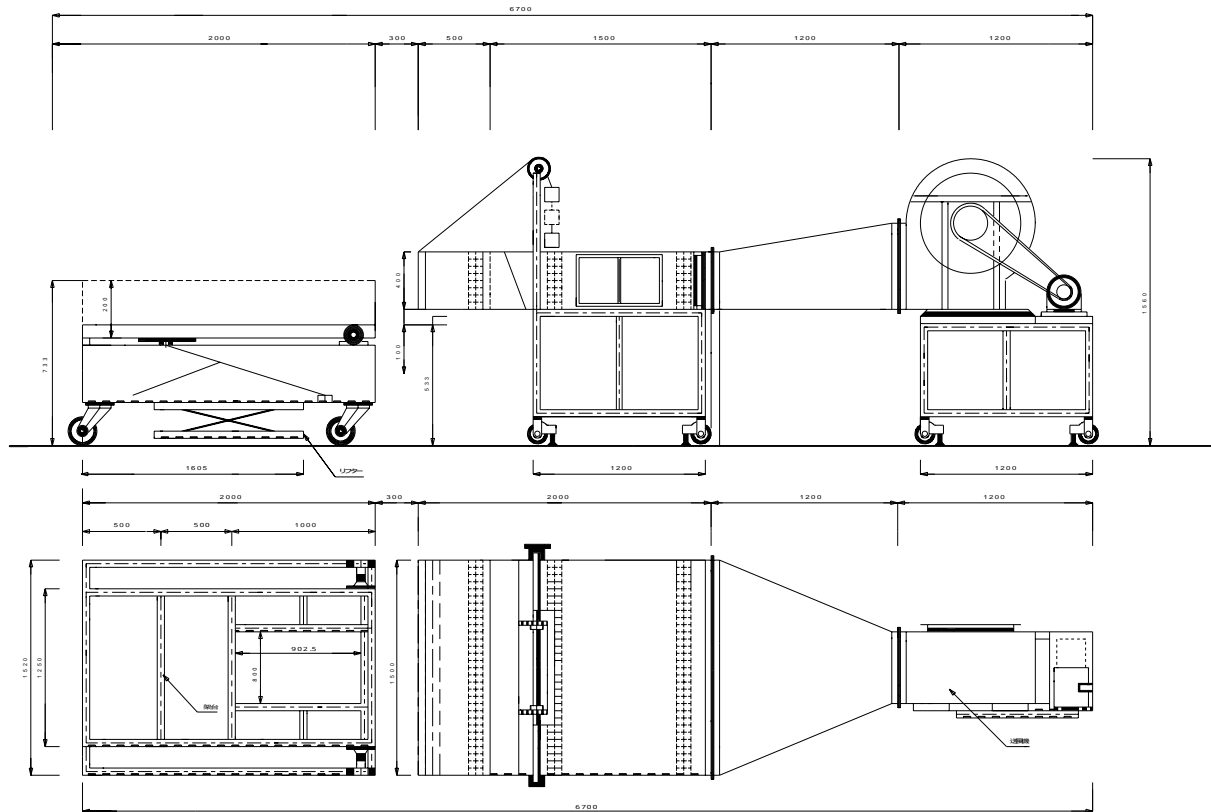

Fire Resistance Test System for Roofs (Dimensions in mm)

## 5 . Performance Evaluation Report

The performance evaluation report shall include the next item. Formats and other can be determined separately.

- (1) Name of Performance evaluation body, Evaluation No., Completion date
- (2) Category of performance evaluation
- (3) Evaluation report (summary of an test result, discussion, conclusion)
- (4) Applicant (company name, representative name, address)
- (5) Title (name of construction method etc.)
- (6) Structure of construction illustration (attachment)
- (7) Specifications (attachment) constitution method etc.
- (8) Installation method (attachment)
- (9) Test report (attachment)